

PRO V200 VINYLESTER RESIN TECHNICAL DATA

PRODUCT DESCRIPTION

PRO V200 is a two component high strength 10:1 ratio vinylester chemical anchoring resin system. It has been developed as a fast curing high strength resin anchor for high loads and critical applications including over head use. It is especially effective in corrosive environments and damp conditions.

Pack size: 410ml 10:1 Co-axial cartridge + 1 mixer

SPECIFIC BENEFITS

European approved
High bond strength
High chemical resistance
WRAS approved
Use with studs and rebar
Cracked or non-cracked concrete
Fire approved
Suitable for underwater use
A+ Rating VOC content

APPROVALS

ETA Option 1 cracked concrete / TR029
(Includes flooded holes and wet and dry concrete conditions)
ETA TR023 post installed rebar installations
WRAS approved for use with potable drinking water
R240 Fire Test report SIGGMA
CE certified



SHELF LIFE AND STORAGE

This product should be stored between +5°C & +25°C.

The shelf life of the product is 12 months from the manufacture date.

CONTENTS

	<i>Page</i>
Features and Benefits	2
Loads, edge and spacings based on characteristic bond strengths showing steel failure	2
Design resistance of PRO V200 resin used with various stud strengths, material and rebar	3,4,5
Characteristic and design load resistances based on characteristic bond strengths for hef 4d (minimum embedment) to 20d	6
Bond strength factors	7
Characteristic and design load resistances for rebar based on characteristic bond strengths for hef 4d (minimum embedment) to 20d	8
Bond strength factors for rebar	9
Material properties for threaded rods and rebar	10
Tension, edge and spacing reduction factors	11
Post installed rebar data	12
Curing time / temperature range	16
Installation parameters: drilling, hole cleaning and installation	17
Table notes	18

IMPORTANT: The information and data given is based on our own experience, research and testing and is believed to be reliable and accurate. However, as we cannot know the varied uses to which the product may be applied, or the methods of application used, no warranty as to the fitness or suitability of the product is given or implied. It is the users responsibility to determine suitability of use. For further information please contact our technical department.

Version 6 : 01/03/2021

Features and Benefits

- High bond strength with high load resistance
- Used with all grades of threaded rod and rebar in accordance with TR029
- Used in non-cracked and cracked concrete
- Fast gelling and curing
- Used in dry and wet concrete
- Used in critical or overhead applications
- Used in corrosive environments
- Guaranteed life of anchor 50 years
- Used for elevated temperatures - temperature ranges I, II and III
- Used for post installed rebar installations under TR029 and TR023
- Low shrinkage enables large diameter installations
- Close edge distance and small spacing
- Manual cleaning up to 20mm diameter and embedment depths of 240mm
- Independently tested and approved

Loads, edge and spacings based on characteristic bond strengths - showing steel failure

Stud Ø (mm)	Characteristic Resistance (kN)		Design Resistance (kN)		Recommended Load (kN)		Characteristic distances (mm)			Min Edge and Spacing		Nominal Embedment (mm)	Hole Diameter concrete (mm)	Hole Diameter fixture (mm)	Max Torque (Nm)
	Tension	Shear	Tension	Shear	Tension	Shear	Edge	Spacing	Edge	(mm)					
	Nrk	Vrk	Nrd	Vrd	Nrec	Vrec	Ccr,N	Scr,N	Ccr,V	Cmin, Smin					
8	19.00		12.70		9.07							60			
	19.00	9.00	12.70	7.20	9.07	5.14	80	160	80	40	80	10	9	10	
	19.00		12.70		9.07						160				
10	22.62		15.08		10.77							60			
	30.20	15.00	20.10	12.00	14.36	8.57	100	200	90	50	90	12	12	20	
	30.20		20.10		14.36						200				
12	29.82		19.88		14.20							70			
	43.80	21.00	29.20	16.80	20.86	12.00	120	240	110	60	110	14	14	40	
	43.80		29.20		20.86						240				
16	43.43		28.95		20.68							80			
	67.86	39.00	45.24	31.20	32.31	22.29	160	320	125	80	125	18	18	80	
	81.60		54.40		38.86						320				
20	55.42		36.95		26.39							90			
	104.68	61.00	69.79	48.80	49.85	34.86	200	400	180	100	170	24	22	120	
	127.40		84.90		60.64						400				
24	63.33		42.22		30.16							100			
	133.00	88.00	88.67	70.40	63.33	50.29	230	460	220	120	210	28	26	160	
	183.60		122.40		87.43						480				
27	70.91		47.27		33.77							110			
	154.72	115.00	103.15	92.00	73.68	65.71	270	540	240	135	240	32	30	180	
	238.00		159.10		113.64						540				
30	78.04		52.02		37.16							120			
	182.09	142.50	121.39	114.00	86.71	81.43	280	560	280	150	280	35	32	200	
	292.00		194.50		138.93						600				
33	88.95		59.30		42.36							130			
	205.27	173.50	136.85	138.80	97.75	121.43	310	620	310	165	300	37	36	250	
	360.00		240.60		171.86						660				
36	108.57		72.38		51.70							150			
	246.10	212.50	164.07	170.00	117.19	121.43	330	660	330	180	340	40	38	300	
	425.00		283.33		202.38						720				

All data is based on correct installation - see instructions page 13
 No influence of edge and spacing. Minimum base material thickness hef +30mm >100mm for M8 to M12 and for M16 to M30 hef +2 d. hef range minimum or 4d whichever is greatest to 20d
 Concrete strength C20/25 - fc cube = 25N/mm² (25MPa)
 5.8 grade stud
 Temperature range I : maximum long term temperature:+24°C / maximum short term temperature +40°C

Please refer to table notes on the back page

 = steel failure

Design Resistance of PRO V200 resin used with various stud strengths, material and rebar.

5.8 grade steel studding

Stud Diam (mm)	Hole Diam (mm)	Embedment depth hef (mm)																				hef failure (mm)	Fd,s Design Load (kN)
		60	70	80	90	100	110	120	130	140	160	200	240	280	320	400	480	540	600	660	720		
8	10	12.7																				59	12.7
10	12	15.1	17.6	20.1																		80	20.1
12	14		19.9	22.7	25.6	28.4	29.2															103	29.2
16	18			29.0	32.6	36.2	39.8	43.4	47.1	50.7	54.4											150	54.4
20	24			32.8	36.9	41.1	45.2	49.3	53.4	57.5	65.7	82.1	84.9									207	84.9
24	28					42.2	46.5	50.7	54.9	59.1	67.6	84.5	101.3	118.2	122.4							290	122.4
27	32						47.3	51.6	55.9	60.2	68.8	86.0	103.2	120.3	137.5	159.1						370	159.1
30	35							52.0	56.4	60.7	69.4	86.7	104.1	121.4	138.8	173.4	194.5					449	194.5
33	38								59.3	63.9	73.0	91.2	109.5	127.7	146.0	182.5	219.0	240.6				527	240.6
36	40									67.6	77.2	96.5	115.8	135.1	154.4	193.0	231.6	260.6	283.2			587	283.2
Depth (mm)		60	70	80	90	100	110	120	130	140	160	200	240	280	320	400	480	540	600	660	720		

8.8 grade steel studding

Stud Diam (mm)	Hole Diam (mm)	Embedment depth hef (mm)																				hef failure (mm)	Fd,s Design Load (kN)
		60	70	80	90	100	110	120	130	140	160	200	240	280	320	400	480	540	600	660	720		
8	10	12.9	15.0	17.2	19.3	19.5																91	19.5
10	12	15.1	17.6	20.1	22.6	25.1	27.6	30.2	30.9													123	30.9
12	14		19.9	22.7	25.6	28.4	31.2	34.1	36.9	39.8	45.0											158	45.0
16	18			29.0	32.6	36.2	39.8	43.4	47.1	57.9	57.9	72.4	83.7									231	83.7
20	24			32.8	36.9	41.1	45.2	49.3	53.4	57.5	65.7	82.1	98.5	114.9	130.7							318	130.7
24	28					42.2	46.5	50.7	54.9	59.1	67.6	84.5	101.3	118.2	135.1	168.9	188.3					446	188.3
27	32						47.3	51.6	55.9	60.2	68.8	86.0	103.2	120.3	137.5	171.9	206.3	232.1				570	244.8
30	35							52.0	56.4	60.7	69.4	86.7	104.1	121.4	138.8	173.4	208.1	234.1	260.2			690	299.2
33	38								59.3	63.9	73.0	91.2	109.5	127.7	146.0	182.5	219.0	246.4	273.7	301.1		811	370.1
36	40									67.6	77.2	96.5	115.8	135.1	154.4	193.0	231.6	260.6	289.5	318.5	347.4	903	435.7
Depth (mm)		60	70	80	90	100	110	120	130	140	160	200	240	280	320	400	480	540	600	660	720		

= steel failure

Design Resistance of PRO V200 resin used with various stud strengths, material and rebar.

10.9 grade steel studding

Stud Diam (mm)	Hole Diam (mm)	Embedment depth hef																			hef failure (mm)	Fd,s Design Load (kN)		
		60	70	80	90	100	110	120	130	140	160	200	240	280	320	400	480	540	600	660			720	
8	10	12.9	15.0	17.2	19.3	21.4	23.6	25.7	27.2												127	27.2		
10	12	15.1	17.6	20.1	22.6	25.1	27.6	30.2	32.7	35.2	40.2	43.1									171	43.1		
12	14		19.9	22.7	25.6	28.4	31.2	34.1	36.9	39.8	45.4	56.8	62.6								220	62.6		
16	18			29.0	32.6	36.2	39.8	43.4	47.1	50.7	57.9	72.4	86.9	101.3	115.8	116.6					322	116.6		
20	24				32.8	36.9	41.1	45.2	49.3	53.4	57.5	65.7	82.1	98.5	114.9	131.4	164.2				443	182.0		
24	28						42.2	46.5	50.7	54.9	59.1	67.6	84.5	101.3	118.2	131.1	168.9	202.7			621	262.2		
27	32							47.3	51.6	55.9	60.2	68.8	86.0	103.2	120.3	137.5	171.9	206.3	232.1		793	341.0		
30	35								52.0	56.4	60.7	69.4	86.7	104.1	121.4	138.8	173.4	208.1	234.1	260.2	961	416.7		
33	38									59.3	63.9	73.0	91.2	109.5	127.7	146.0	182.5	219.0	246.4	273.7	301.1	1130	515.5	
36	40										67.6	77.2	96.5	115.8	135.1	154.4	193.0	231.6	260.6	289.5	318.5	347.4	1258	606.9
Depth (mm)		60	70	80	90	100	110	120	130	140	160	200	240	280	320	400	480	540	600	660	720			

A4-70 stainless steel studding

Stud Diam (mm)	Hole Diam (mm)	Embedment depth hef																			hef failure (mm)	Fd,s Design Load (kN)	
		60	70	80	90	100	110	120	130	140	160	200	240	280	320	400	480	540	600	660			720
8	10	12.9	13.7																		64	13.7	
10	12	15.1	17.6	20.1	21.7																86	21.7	
12	14		19.9	22.7	25.6	28.4	31.2	31.6													111	31.6	
16	18			29.0	32.6	36.2	39.8	43.4	47.1	50.7	57.9	58.8									162	58.8	
20	24				32.8	36.9	41.1	45.2	49.3	53.4	57.5	65.7	82.1	91.7							223	91.7	
24	28						42.2	46.5	50.7	54.9	59.1	67.6	84.5	101.3	118.2	132.1					313	132.1	
27	32							47.3	51.6	55.9	60.2	68.8	80.2								* 1	187	80.2
30	35								52.0	56.4	60.7	69.4	86.7	98.1							* 1	226	98.1
33	38									59.3	63.9	73.0	91.2	109.5	121						* 1	266	121.3
36	40										67.6	77.2	96.5	115.8	135.1	143					* 1	296	142.8
Depth (mm)		60	70	80	90	100	110	120	130	140	160	200	240	280	320	400	480	540	600	660	720		

= steel failure

* 1 = Tensile strength 500N/mm2

Please refer to table notes on the back page

Design Resistance of PRO V200 resin used with various stud strengths, material and rebar.

A4-80 stainless steel studding

Stud Diam (mm)	Hole Diam (mm)	Embedment depth hef (mm)																			hef failure (mm)	Fd,s Design Load (kN)	
		60	70	80	90	100	110	120	130	140	160	200	240	280	320	400	480	540	600	660			720
8	10	12.9	15.0	15.7																	73	15.7	
10	12		17.6	2.1	22.6	24.8															99	24.8	
12	14		19.9	22.7	25.6	28.4	31.2	34.1	36.1												127	36.1	
16	18			29.0	32.6	36.2	39.8	43.4	47.1	50.7	57.9	67.2									186	67.2	
20	24			32.8	36.9	41.1	45.2	49.3	53.4	57.5	65.7	82.1	98.5	104.8							255	104.8	
24	28					42.2	46.5	50.7	54.9	59.1	67.6	84.5	101.3	118.2	132.1						* 2	313	132.1
27	32						47.3	51.6	55.9	60.2	68.8	80.2									* 1	187	80.2
30	35							52.0	56.4	60.7	69.4	86.7	98.1								* 1	226	98.1
33	38								59.3	63.9	73.0	91.2	109.5	121.3							* 1	266	121.3
36	40									67.6	77.2	96.5	115.8	135.1	142.8						* 1	296	142.8
Depth (mm)		60	70	80	90	100	110	120	130	140	160	200	240	280	320	400	480	540	600	660	720		

High bond reinforcing bars Fyk=500N/mm2

Stud Diam (mm)	Hole Diam (mm)	Embedment depth hef (mm)																			hef failure (mm)	Fd,s Design Load (kN)		
		60	70	80	90	100	110	120	130	140	160	200	240	280	320	400	500	560	640	720			800	
8	12	8.7	10.2	11.7	13.1	14.6	16.0	17.5	19.0	20.4	21.9										150	21.9		
10	14	10.4	12.1	13.8	15.6	17.3	19.0	20.7	22.5	24.2	27.6	34.1									198	34.1		
12	16		13.7	15.7	17.6	19.6	21.6	23.5	25.5	27.4	31.4	39.2	47.1	49.2							251	49.2		
16	20			19.3	21.7	24.1	26.5	29.0	31.4	33.8	38.6	48.3	57.9	67.6	77.2						362	87.4		
20	25			21.0	23.6	26.2	28.9	31.5	34.1	36.7	42.0	52.5	63.0	73.5	84.0	105.0					521	136.6		
25	30					28.3	31.1	33.9	36.8	39.6	45.2	56.6	67.9	79.2	90.5	113.1	141.4					695	196.5	
28	35						33.4	36.4	39.5	42.5	48.6	60.7	72.8	85.0	97.1	121.4	151.8	170.0				882	267.8	
32	40								43.1	46.5	53.1	66.4	79.6	92.9	106.2	132.7	165.9	185.8	212.3			1054	349.7	
36	44									52.3	59.7	74.7	89.6	104.5	119.4	149.3	186.6	209.0	238.9	268.8			1188	443.5
40	50										66.4	82.9	99.5	116.1	132.7	165.9	207.4	232.3	265.4	298.6	331.8		1317	546.3
Depth (mm)		60	70	80	90	100	110	120	130	140	160	200	240	280	320	400	500	560	640	720	800			

= steel failure

* 1 = Tensile strength 500N/mm²

* 2 = Tensile strength 700N/mm²

Please refer to table notes on the back page

Characteristic and design load resistances based on characteristic bond strengths for hef 4d (minimum embedment) to 20d

Stud Ø (mm)	Non cracked concrete						Cracked concrete						Nominal Embed- ment (mm)
	Characteristic Resistance (kN)		Design Resistance (kN)		Recommended Load (kN)		Characteristic Resistance (kN)		Design Resistance (kN)		Recommended Load (kN)		
	Tension	Shear	Tension	Shear	Tension	Shear	Tension	Shear	Tension	Shear	Tension	Shear	
	Nrk	Vrk	Nrd	Vrd	Nrec	Vrec	Nrk	Vrk	Nrd	Vrd	Nrec	Vrec	
M8	19.30	9.00	12.87	7.20	9.19	5.14	Not Applicable		Not Applicable		Not Applicable		60
	25.74		17.16		12.26		Not Applicable		Not Applicable		Not Applicable		80
	51.47		34.31		24.51		Not Applicable		Not Applicable		Not Applicable		160
M10	22.62	15.00	15.08	12.00	10.77	8.57	10.40	15.00	6.94	12.00	4.96	8.57	60
	33.93		22.62		16.16		15.60		10.40		7.43		90
	75.40		50.27		35.90		34.68		23.12		16.52		200
M12	29.82	21.00	19.88	16.80	14.20	12.00	13.12	21.00	8.75	16.80	6.24	12.00	70
	46.86		31.24		22.31		20.62		13.75		9.82		110
	102.24		68.16		48.69		44.98		29.98		21.42		240
M16	43.43	39.00	28.95	31.20	20.68	22.29	17.37	39.00	11.58	31.20	8.27	22.29	80
	67.86		45.24		32.31		27.14		18.10		12.93		125
	173.72		115.81		82.72		69.50		46.33		33.10		320
M20	55.42	61.00	36.95	48.80	26.39	34.86	21.06	61.00	14.04	48.80	10.00	34.86	90
	104.68		69.79		49.85		39.78		26.52		18.94		170
	246.30		164.20		117.29		93.60		62.40		44.59		400
M24	63.33	88.00	42.22	70.40	30.16	50.29	Not Applicable		Not Applicable		Not Applicable		100
	133.00		88.67		63.33		Not Applicable		Not Applicable		Not Applicable		210
	304.01		202.67		144.76		Not Applicable		Not Applicable		Not Applicable		480
M27	70.91	115.00	47.27	92.00	33.77	65.71	Not Applicable		Not Applicable		Not Applicable		110
	154.72		103.15		73.68		Not Applicable		Not Applicable		Not Applicable		240
	348.11		232.08		165.77		Not Applicable		Not Applicable		Not Applicable		540
M30	78.04	142.50	52.02	114.00	37.16	81.43	Not Applicable		Not Applicable		Not Applicable		120
	182.09		121.39		86.71		Not Applicable		Not Applicable		Not Applicable		280
	390.19		260.12		185.80		Not Applicable		Not Applicable		Not Applicable		600
M33	88.95	173.50	59.30	138.80	42.36	99.14	Not Applicable		Not Applicable		Not Applicable		130
	205.27		136.85		97.75		Not Applicable		Not Applicable		Not Applicable		300
	451.60		301.07		215.05		Not Applicable		Not Applicable		Not Applicable		660
M36	108.57	212.5	72.38	170.00	51.70	121.43	Not Applicable		Not Applicable		Not Applicable		150
	246.10		164.07		117.19		Not Applicable		Not Applicable		Not Applicable		340
	521.15		347.44		248.17		Not Applicable		Not Applicable		Not Applicable		720

All data is based on correct installation - see instructions
 No influence of edge and spacing
 Minimum base material thickness hef +30mm >100mm for M8 to M12 and for M16 to M30 hef +2 d
 hef range minimum or 4d whichever is greatest to 20d
 Concrete strength C20/25 - f_c cube = 25N/mm² (25MPa)
 Temperature range 1, maximum long term / short term temperature +24/40°C

Bond strength factors

Influence of concrete strength on combined pull out and concrete cone resistance

Concrete Strength N/mm2 (Mpa)	C15/20	C20/25	C25/30	C30/37	C35/45	C40/50	C45/55	C50/60
non cracked $f_c =$	0.94	1.00	1.06	1.12	1.17	1.23	1.26	1.30
cracked $f_c =$	0.96	1.00	1.03	1.05	1.06	1.07	1.08	1.09

Influence of environmental conditions in non cracked concrete

		M8	M10	M12	M16	M20	M24	M27	M30	M33	M36
Temp I 40°C / 24°C	Dry and Wet	1.00	1.00	1.00	1.00	1.00	1.00	1.00	1.00	1.00	1.00
Temp II 80°C / 50°C	Dry and Wet	0.90	0.88	0.87	0.86	0.85	0.84	0.83	0.82	0.81	0.80

Influence of environmental conditions in cracked concrete

		M8	M10	M12	M16	M20	M24	M27	M30
Temp I 40°C / 24°C	Dry and Wet	n/a	0.46	0.44	0.40	0.38	n/a	n/a	n/a
Temp II 80°C / 50°C	Dry and Wet	n/a	0.45	0.43	0.40	0.38	n/a	n/a	n/a

Bond strength factors
Select concrete strength and environmental condition and apply to bond strength table on page 6

Characteristic and design load resistances for rebar based on characteristic bond strengths for hef 4d (min embedment) to 20d

Rebar Ø (mm)	Non cracked concrete						Cracked concrete						Nominal Embed- ment (mm)												
	Characteristic Resistance (kN)		Design Resistance (kN)		Recommended Load (kN)		Characteristic Resistance (kN)		Design Resistance (kN)		Recommended Load (kN)														
	Tension Nrk	Shear Vrk	Tension Nrd	Shear Vrd	Tension Nrec	Shear Vrec	Tension Nrk	Shear Vrk	Tension Nrd	Shear Vrd	Tension Nrec	Shear Vrec													
8	15.68	13.95	8.71	9.30	6.22	6.64	Not Applicable	Not Applicable	Not Applicable	Not Applicable	Not Applicable	Not Applicable	60												
	20.91		11.62		8.30								80												
	41.82	23.23	16.60	160																					
10	18.66	21.45	10.37	14.30	7.41	10.21							Not Applicable	Not Applicable	Not Applicable	Not Applicable	Not Applicable	Not Applicable	60						
	27.99		15.55		11.11														90						
	62.20		34.56		24.68														200						
12	24.70	31.05	13.72	20.70	9.80	14.79													10.56	31.05	5.86	20.70	4.19	14.79	70
	38.82		21.56		15.40														16.59		9.22		6.58		110
	84.69		47.05		33.61														36.19	20.11	14.36	240			
14	31.67	42.45	17.59	28.30	12.57	20.21													13.72	42.45	7.62	28.10	5.45	20.07	80
	45.52		25.29		18.06		19.73	10.96	7.83	115															
	110.84		61.58		43.98		48.03	26.68	19.06	280															
16	34.74	55.50	19.30	37.00	13.79	26.43	15.28	55.50	8.49	37.00	6.06	26.43							80						
	54.29		30.16		21.54		23.88		13.26		9.47		125												
	138.97		77.21		55.15		61.12		33.96		24.26		320												
18	37.55	69.66	20.86	46.44	14.90	33.17	16.51	69.66	9.17	46.44	6.55	33.17	80												
	70.40		39.11		27.94		30.96		17.20		12.29		150												
	168.97		93.87		67.05		74.31		41.28		29.49		360												
20	36.76	86.55	20.42	57.70	14.59	41.21	19.79	86.55	11.00	57.70	7.85	41.21	90												
	69.43		38.57		27.55		37.39		20.77		14.84		170												
	163.36		90.76		64.83		87.96		48.87		34.91		400												
22	44.92	104.01	24.96	69.34	17.83	49.53	24.19	104.00	13.44	69.34	9.60	49.53	100												
	85.36		47.42		33.87		45.96		25.53		18.24		190												
	197.67		109.82		78.44		106.44		59.13		42.24		440												
25	51.05	135.00	28.36	90.00	20.26	64.29	27.49	135.00	15.27	90.00	10.91	64.29	100												
	107.21		59.56		42.54		57.73		32.07		22.91		210												
	255.26		141.81		101.29		137.45		76.36		54.54		500												
28	61.08	168.75	33.93	112.50	24.24	80.36	Not Applicable	Not Applicable	Not Applicable	Not Applicable	Not Applicable	Not Applicable	112												
	152.71		84.84		60.60								280												
	305.41		169.67		121.20								560												
32	77.21	220.95	42.89	147.30	30.64	105.21							Not Applicable	Not Applicable	Not Applicable	Not Applicable	Not Applicable	Not Applicable	128						
	193.02		107.23		76.60														320						
	386.04		214.47		153.19														640						

Please refer to table notes on the back page

Bond strength factors - rebar

Influence of concrete strength on combined pull out and concrete cone resistance

Concrete Strength N/mm2 (MPa)	C15/20	C20/25	C25/30	C30/37	C35/45	C40/50	C45/55	C50/60
non cracked $f_c =$	0.94	1.00	1.06	1.12	1.17	1.23	1.26	1.30
cracked $f_c =$	0.96	1.00	1.03	1.05	1.06	1.07	1.08	1.09

Influence of environmental conditions in non cracked concrete

		Ø 8	Ø 10	Ø 12	Ø 14	Ø 16	Ø 18	Ø 20	Ø 22	Ø 25	Ø 28	Ø 32
Temp I 40°C / 24°C	Dry and Wet	1.00	1.00	1.00	1.00	1.00	1.00	1.00	1.00	1.00	1.00	1.00
Temp II 80°C / 50°C	Dry and Wet	0.90	0.90	0.88	0.88	0.88	0.86	0.86	0.86	0.86	0.84	0.84

Influence of environmental conditions in cracked concrete

		Ø 8	Ø 10	Ø 12	Ø 14	Ø 16	Ø 18	Ø 20	Ø 22	Ø 25	Ø 28	Ø 32
Temp I 40°C / 24°C	Dry and Wet	n/a	n/a	0.43	0.43	0.43	0.43	0.53	0.53	0.53	n/a	n/a
Temp II 80°C / 50°C	Dry and Wet	n/a	n/a	0.38	0.38	0.38	0.38	0.46	0.46	0.46	n/a	n/a

Please refer to table notes on the back page

Material properties for grades of other threaded rod and rebar

Stud Diameter	Stud Grade 8.8		Stud Grade 10.9		Stud Grade A4-70		Stud Grade A4-80	
	Nrk, s	Nrd, s	Nrk, s	Nrd, s	Nrk, s	Nrd, s	Nrk, s	Nrd, s
(mm)	(kN)	(kN)	(kN)	(kN)	(kN)	(kN)	(kN)	(kN)
M8	29.2	19.5	38.1	27.2	25.6	13.7	29.2	15.6
M10	46.4	30.9	60.3	43.1	40.6	21.7	46.4	24.8
M12	67.4	44.9	87.7	62.6	59.0	31.6	67.4	36.0
M16	125.6	83.7	163.0	116.4	109.9	58.8	125.7	67.2
M20	196.1	130.7	255.0	182.1	171.5	91.7	196.0	104.8
M24	282.5	188.3	367.0	262.1	247.1	132.1	293.0	132.1
M27	367.0	244.7	477.4	341.0	229.4	80.2	229.4	80.2
M30	448.8	299.2	583.0	416.4	280.5	98.1	280.6	98.1
M36	653.6	435.7	849.7	606.9	408.4	142.8	408.4	142.8

Stud Diameter	Stud Grade 8.8		Stud Grade 10.9		Stud Grade A4-70		Stud Grade A4-80	
	Vrk, s	Vrd, s	Vrk, s	Vrd, s	Vrk, s	Vrd, s	Vrk, s	Vrd, s
(mm)	(kN)	(kN)	(kN)	(kN)	(kN)	(kN)	(kN)	(kN)
M8	14.6	11.7	19.0	15.2	12.8	8.2	14.6	9.4
M10	23.2	18.6	30.2	24.1	20.3	13.0	23.2	14.9
M12	33.7	27.0	43.8	35.1	29.5	18.9	33.7	21.6
M16	62.8	50.2	81.6	65.3	55.0	35.2	62.8	40.3
M20	98.0	78.4	127.4	101.9	85.8	55.0	98.0	62.8
M24	141.2	113.0	183.6	146.8	123.6	79.2	141.2	90.5
M27	183.5	146.8	238.7	191.0	114.7	48.4	114.7	48.4
M30	224.4	179.5	291.5	215.9	140.3	89.9	140.3	59.2
M36	326.8	261.4	424.8	283.2	204.2	130.9	204.2	86.2

Rebar Diameter	Rebar BSt 500 to DIN 488		Rebar BSt 500 to DIN 488	
	Nrk, s	Nrd, s	Vrk, s	Vrd, s
(mm)	(kN)	(kN)	(kN)	(kN)
8	28.0	20.0	14.0	9.3
10	43.0	30.7	21.5	14.3
12	62.0	44.3	31.0	20.7
14	85.0	60.7	42.5	28.3
16	111.0	79.3	55.5	37.0
18	139.5	100.0	70.0	46.7
20	173.0	123.6	86.5	57.7
22	208.6	149.3	104.5	69.7
25	270.0	192.9	135.0	90.0
28	339.0	242.1	169.0	112.7
32	442.0	315.7	221.0	147.3
36	563.2	443.5	281.6	187.7
40	693.8	546.3	346.9	231.3

All grades shown for information

M30 studding is 8.8 grade instead of 5.8 grade
M30 for A4-70 tensile strength of 500N/mm²,
(500MPa) instead of 700N/mm² (700MPa)

Safety factor is 1.5 tension and 1.25 shear for all
carbon steel

Safety factor is 1.56 for stainless steel, up to M24,
M30 and M36 is 2.0

Safety factor is 1.4 tension and 1.5 shear for BSt 500
rebar

Partial safety factors pages 2,3,4,5,6,7:

1.8 for 8mm-16mm rebar and studs

2.1 for 16mm and above rebar and studs

Anchor spacing and edge distance reduction factors

Effect of anchor spacing - tension

Anchor Spacing (mm)	Stud / Rebar Diameter										
	8	10	12	16	20	24	27	30	33	36	40
40	0.64										
50	0.67	0.63									
60	0.70	0.65	0.63								
70	0.73	0.67	0.64								
80	0.76	0.69	0.66	0.63							
90	0.79	0.72	0.68	0.64							
100	0.82	0.74	0.70	0.65	0.63						
120	0.87	0.79	0.74	0.68	0.65	0.63					
150	0.96	0.86	0.80	0.73	0.68	0.65	0.64	0.63			
160	1.00	0.88	0.82	0.74	0.70	0.66	0.65	0.63	0.62		0.63
180		0.93	0.86	0.77	0.72	0.68	0.65	0.65	0.64	0.64	0.64
200		1.00	0.90	0.80	0.74	0.69	0.67	0.66	0.65	0.65	0.65
225			0.95	0.84	0.77	0.72	0.69	0.68	0.67	0.67	0.66
240			1.00	0.86	0.79	0.73	0.71	0.69	0.69	0.68	0.67
250				0.87	0.80	0.74	0.72	0.70	0.70	0.68	0.68
275				0.91	0.83	0.76	0.74	0.72	0.72	0.70	0.69
280				0.92	0.84	0.77	0.75	0.73	0.72	0.70	0.69
300				0.95	0.86	0.79	0.76	0.74	0.74	0.72	0.71
320				1.00	0.88	0.81	0.78	0.76	0.75	0.73	0.72
350					0.92	0.83	0.81	0.78	0.78	0.75	0.73
400					1.00	0.88	0.86	0.82	0.82	0.78	0.76
440						0.92	0.89	0.85	0.85	0.81	0.79
460						1.00	0.91	0.87	0.87	0.82	0.80
500							0.95	0.90	0.90	0.85	0.82
540							1.00	0.93	0.93	0.88	0.84
560								1.00	0.95	0.89	0.86
620									1.00	0.93	0.89
660										1.00	0.91
720											1.00

Effect of edge distance - tension

Edge Distance (mm)	Stud / Rebar Diameter										
	8	10	12	16	20	24	27	30	33	36	40
40	0.64										
50	0.73	0.63									
60	0.82	0.70	0.63								
70	0.90	0.77	0.68								
80	1.00	0.84	0.74	0.63							
90		0.91	0.80	0.67							
100		1.00	0.86	0.71	0.63						
110			0.92	0.76	0.66						
120			1.00	0.80	0.70	0.64					
140				0.89	0.77	0.67	0.63	0.63			
160				1.00	0.84	0.72	0.70	0.65	0.62		
180					0.91	0.78	0.75	0.66	0.70	0.67	0.68
200					1.00	0.84	0.81	0.76	0.76	0.78	0.71
220						0.89	0.86	0.81	0.81	0.82	0.75
240						1.00	0.92	0.86	0.86	0.87	0.78
270							1.00	.94	0.94	0.93	0.83
280								1.00	0.97	0.96	0.85
310									1.00	0.98	0.90
330										1.00	0.93
360											1.00

Effect of edge distance - shear

Anchor Spacing (mm)	Stud / Rebar Diameter										
	8	10	12	16	20	24	27	30	33	36	40
40	0.25										
50	0.44	0.30									
60	0.63	0.48	0.30								
70	0.81	0.65	0.44								
80	1.00	0.83	0.58	0.40							
90		1.00	0.72	0.53							
100			0.86	0.67	0.35						
110			1.00	0.80	0.44						
125				1.00	0.58	0.35					
140					0.72	0.46	0.44	0.30			
160					0.91	0.62	0.57	0.35	0.34		
180					1.00	0.77	0.69	0.46	0.41	0.33	
200						0.92	0.82	0.57	0.50	0.42	0.32
220						1.00	0.94	0.68	0.59	0.51	0.53
240							1.00	0.78	0.68	0.60	0.59
280								1.00	0.86	0.78	0.72
310									1.00	0.91	0.82
330										1.00	0.89
360											1.00

Please refer to table notes on the back page

Post installed rebar connections

Minimum anchorage length (l) and lap splice length for C20/25 and maximum installation length (l max)

Rebar		$l_{b,min}$ (mm)	$l_{o,min}$ (mm)	$l_{max,min}$ (mm)	
$\varnothing d_s$ (mm)	f_{yk} (N/mm ²)				
8	500	163	200	1000	N/mm ² = MPa
10	500	204	204	1000	
12	500	170	200	1200	
14	500	198	210	1400	
16	500	227	240	1600	

1) According to EN 1992-1-1:2004 $l_{b,min}$ (8.6) and $l_{o,min}$ (8.11) for good bond conditions and $a_g = 1,0$ with maximum yield stress for rebar B500 B and $\gamma_M = 1,15$

Design values of the ultimate bond resistance f_{bd} ¹⁾ in N/mm² for all drilling methods for good conditions

Rebar Φ	Concrete Class								
	C12/15	C16/20	C20/25	C25/30	C30/37	C35/45	C40/50	C45/60	C50/60
8mm	1.6	1.6	1.6	1.6	1.6	1.6	1.6	1.6	1.6
10mm	1.6	1.6	1.6	1.6	1.6	1.6	1.6	1.6	1.6
12mm	1.6	2	2.3	2.3	2.3	2.3	2.3	2.3	2.3
14mm	1.6	2	2.3	2.7	3	3.4	3.4	3.4	3.4
16mm	1.6	2	2.3	2.7	3	3.4	3.7	4	4.3

1) Tabulated values for f_{bd} are valid for good bond condition according to EN1992-1-1:2004. For all other bond conditions multiply the values for f_{bd} by 0.7.

Post installed rebar connections

Values for pre-calculation of anchoring

Rebar Φd_s	$\alpha1=\alpha2=\alpha3=\alpha4=\alpha5=1.0$			$\alpha2$ or $\alpha5=0.7; \alpha1=\alpha3=\alpha4=1.0$		
	Anchorage length l_{bd}	Design value N_{rd}	Mortar volume	Anchorage length l_{bd}	Design value N_{rd}	Mortar volume
(mm)	(mm)	(kN)	(ml)	(mm)	(kN)	(ml)
8	163	6.55	12	163*	9.42	12
	180	7.23	14	175	10.11	13
	250	10.05	19	190	10.98	14
	378	15.19	28	265	15.31	20
10	204*	10.25	18	204*	14.73	18
	220	11.05	20	220	15.89	20
	310	15.57	28	240	17.33	22
	390	19.59	35	280	20.22	25
	473	23.76	43	331	23.90	30
12	170*	14.74	18	170*	21.06	18
	270	23.41	29	230	28.49	24
	370	32.08	39	280	34.68	30
	470	40.75	50	340	42.12	36
	567	49.16	60	397	49.18	42
14	198*	20.03	24	198*	28.61	24
	310	31.36	37	260	37.57	31
	430	43.5	52	330	47.69	40
	550	55.64	66	400	57.81	48
	662	66.97	80	463	66.91	56
16	227*	26.24	31	227*	37.49	31
	360	41.62	49	300	49.55	41
	490	56.65	67	380	62.76	52
	620	71.68	84	450	74.32	61
	756	87.4	103	529	87.37	72

* Minimum anchorage length. The design value is valid for "good bond conditions" according to EN 1992-1-1.

All other condition: multiply value by 0.7. Mortar volume based on equation: $V = 1.2 \cdot (d_o^2 - d_d^2) \cdot \pi \cdot l_b / 4$

Example for:

C20/25;

good bond condition;

Rebar yield strength

500 N/mm2 (500MPa)

Post installed rebar connections

Values for pre-calculation of overlap joints

Rebar Φd_s	$\alpha1=\alpha2=\alpha3=\alpha4=\alpha5=1.0$			$\alpha2$ or $\alpha5=0.7; \alpha1=\alpha3=\alpha4=1.0$		
	Anchorage length l_{bd}	Design value N_{rd}	Mortar volume	Anchorage length l_{bd46}	Design value N_{rd}	Mortar volume
(mm)	(mm)	(kN)	(ml)	(mm)	(kN)	(ml)
8	200	8.04	15	200	11.56	15
	240	9.65	18	220	12.71	17
	290	11.66	22	230	13.29	17
	378	15.19	29	265	15.31	20
10	204	10.25	18	204	14.73	18
	270	13.56	24	230	16.61	21
	340	17.08	31	270	19.50	24
	400	20.10	36	300	21.67	27
	473	23.76	43	331	23.90	30
12	200	17.33	21	200	24.77	21
	290	25.13	31	250	30.97	26
	380	32.93	40	300	37.16	32
	480	41.6	51	350	43.35	37
	567	49.14	60	397	49.18	42
14	210	21.24	25	210	30.35	25
	320	32.37	39	270	39.02	33
	440	44.51	53	340	49.13	41
	550	55.64	66	400	57.81	48
	662	66.97	80	463	66.91	56
16	240	27.75	33	240	39.64	33
	370	42.78	50	310	51.2	42
	500	57.81	68	380	62.76	52
	630	72.83	86	460	75.97	62
	756	87.4	103	529	87.37	72

* Minimum anchorage length. The design value is valid for "good bond conditions" according to EN 1992-1-1.

All other condition: multiply value by 0.7. Mortar volume based on equation: $V = 1.2 \cdot (d_o^2 - d_d^2) \cdot \pi \cdot l_b / 4$

Example for:

C20/25;

good bond condition;

Rebar yield strength

500 N/mm² (500MPa)

Post installed rebar schematics

Application examples of post-installed rebar

Figure 1: Overlap joints in slabs and beams.

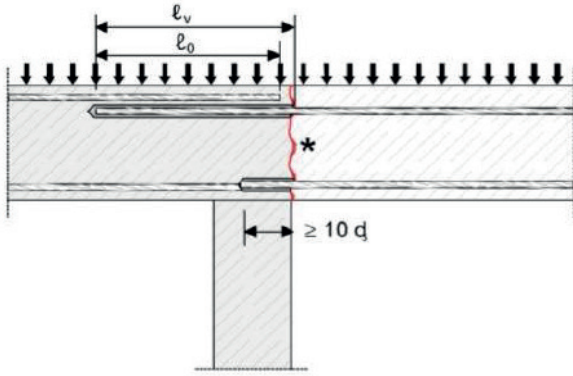

Figure 2: Overlap joint in foundation of a column or wall where the rebar are stressed in tension.

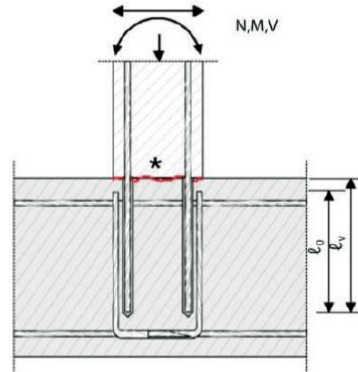

Figure 3: End anchoring of slabs or beams, designed as simply supported.

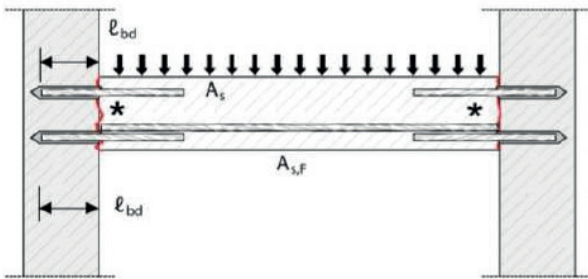

Figure 4: Rebar connection of components stressed primarily in compression. The rebar are stressed in compression.

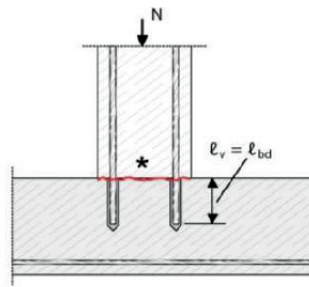
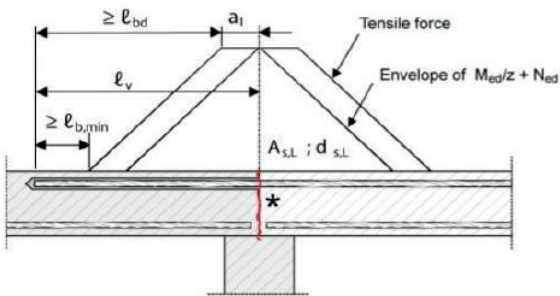

Figure 5: Anchoring of reinforcement to cover the line of acting tensile force.



Note:
In the figures no transverse reinforcement is plotted, the transverse reinforcement as required by EC 2 shall be present.
The shear transfer between old and new concrete shall be designed according to EC 2.

* roughened joint

Minimum curing time

Concrete Temperature	Gel Working Time	Minimum curing time in dry concrete	Minimum curing time in wet concrete
- 10°C *	50 min	240 min	x2
-5°C *	40 min	180 min	x2
5°C	20 min	90 min	x2
15°C	9 min	60 min	x2
25°C	5 min	30 min	x2
35°C	3 min	20 min	x2

Full cure 24 hours
 All specifications based on supplied mixer
 * Resin temperature must be at least 20°C

Temperature ranges

Temperature Range	Concrete Service Temperature	Maximum Long Term Concrete Temp	Maximum Short Term Concrete Temp
Range I	-40°C to +40°C	+24°C	+40°C
Range II	-40°C to +80°C	+50°C	+80°C

Service temperature range: Range of ambient temperatures after installation and during the lifetime of the anchor.

Short term temperature: Temperatures within the service temperature range which vary over short intervals, e.g. day/night cycles and freeze/thaw cycles.

Long term temperature: Temperature, within the service temperature range, which will be approximately constant over significant periods of time. Long term temperatures will include constant or near constant temperatures, such as those experienced in cold stores or next to heating installations.

Physical properties

	N/mm2 (MPa)	Test Method
Compressive Strength	73.0	EN ISO 604 / ASTM 695
Flexural Strength	25.0	EN ISO 178 / ASTM 790
Flexural Modulus	3850.0	EN ISO 178 / ASTM 790
Tensile Strength	14.6	EN ISO 527 / ASTM 638
E Modulus	8029.7	EN ISO 527 / ASTM 638
VOC Content	A+ Rating	-

IMPORTANT : The information and data given is based on our own experience, research and testing and is believed to be reliable and accurate. However, as we cannot know the varied uses to which this product may be applied, or the installation methods used, no warranty as to the fitness or suitability of this product is given or implied. It is the users responsibility to determine suitability of use. For further information please contact our technical department.

Installation parameters: drilling hole, cleaning and installation

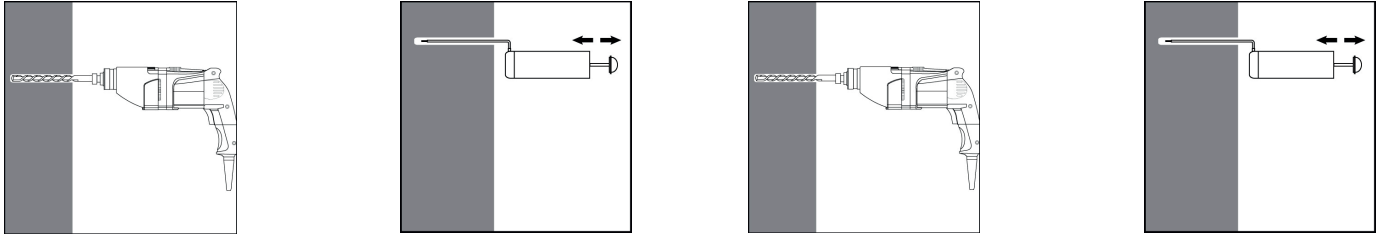

Drill hole in the substrate to the required embedment depth using the appropriate size drill bit.
 Clean the hole. Before setting an anchor, the drilled hole must be free of dust and debris.
 A blow out pump must be used for blowing out drilled holes up to diameters $\leq 24\text{mm}$ and embedment depths up to 10 x drilled hole diameters.
 Blow out at least 4 times from the back of the drilled hole, using an extension if needed.
 Brush 4 times with the specified brush size by inserting the steel brush to the back of the hole (if needed with an extension) in a twisting motion and remove the debris.
 Blow out again with pump at least 4 times.

Cleaning with compressed air is suitable for all bore hole diameters and depths

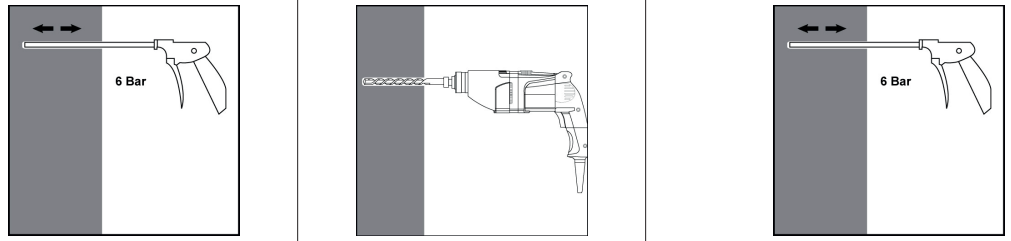

Blow twice from the back of the hole (if needed with a nozzle extension) over the whole length with oil-free compressed air (min. 6 bar at 6 m³/h).
 Brush twice with the specified brush size (see Table 6) by inserting the steel brush to the back of the hole (if required with an extension) in a twisting motion and remove the debris.
 Blow out again with compressed air at least twice.

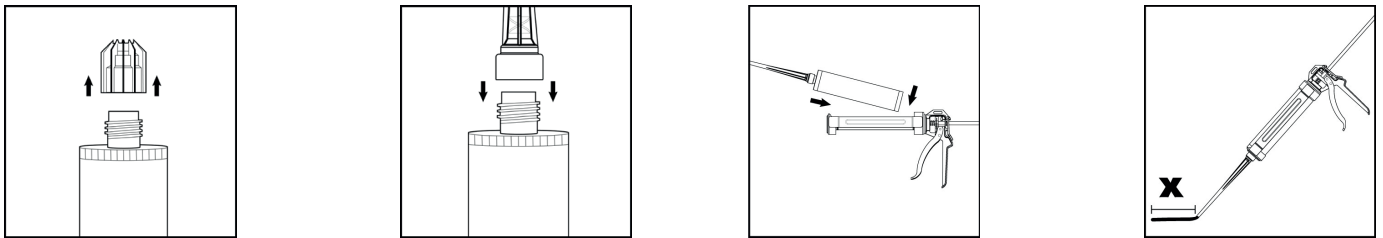

Remove the threaded cap from the cartridge.
 Tightly attach the mixing nozzle.
 Do not modify the mixer in any way. Make sure the mixing element is inside the mixer.
 Use only the supplied mixer. Insert the cartridge into the dispenser gun. Discard the initial trigger pulls (10ml) of resin.

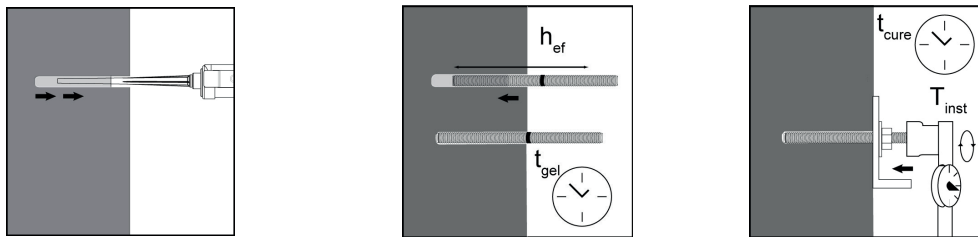

Inject the adhesive starting at the back of the hole, slowly withdrawing the mixer with each trigger pull.
 Fill holes approximately 2/3 full, to ensure that the annular gap between the anchor and the concrete is completely filled with resin along the embedment depth.
 Before use, verify that the threaded rod is dry and free of contaminants. Install the threaded rod to the required embedment depth before the gel working time has elapsed.
 The working time is shown in 'Minimum Curing Time' table on page 12. The anchor can be loaded after the required curing time (see page 12). The applied torque shall not exceed the maximum value given in the table on page 2.

Table Notes

Page 2

Typical characteristic and design resistance performance with 5.8 grade studding and associated installation data

All data is based on correct installation - see instructions

No influence of edge and spacing

Minimum base material thickness hef +30mm >100mm for M8 to M12 and for M16 to M30 hef +2 d

hef range minimum or 4d whichever is greatest to 20d

Concrete strength C20/25 - f_c cube = 25N/mm² (25MPa)

5.8 grade stud

Temperature range I : maximum long term / short term temperature +24/40°C

Page 3

Design Resistance of PRO V500 resin used with various stud strengths, material and rebar.

Note 1 for stainless steel tensile strength is 500N/mm² (500MPa)

Note 2 for stainless steel tensile strength is 700N/mm² (700MPa)

Data shown below the minimum embedment depth is for reference only.

Please refer to our technical department for advice.

Pages 6 and 8

Characteristic and design load resistances based on characteristic bond strengths for hef 4d (minimum embedment) to 20d

All data is based on correct installation - see instructions

No influence of edge and spacing

Minimum base material thickness hef +30mm >100mm for M8 to M12 and for M16 to M30 hef +2 d

hef range minimum or 4d whichever is greatest to 20d

Concrete strength C20/25 - f_c cube = 25N/mm² (25MPa)

Temperature range 1: maximum long term / short term temperature +24/40°C

Pages 7 and 9

Bond Strength Factors

Select concrete strength and environmental conditions and apply bond strength

Page 10

Material properties for grades of other threaded rod and rebar

All grades shown for information

M30 studding is 8.8 grade instead of 5.8 grade. > M27 for A4-70 tensile strength of 500N/mm² instead of 700N/mm²

M30 for A4-70 tensile strength of 500N/mm², (500MPa) instead of 700N/mm² (700MPa)

Safety factor is 1.5 tension and 1.25 shear for all carbon steel

Safety factor is 1.87 for stainless steel, up to M24, M27 to M36 is 2.86

Safety factor is 1.56 for stainless steel in shear, up to M24, M27 to M36 is 2.37

Safety factor is 1.4 tension and 1.5 shear for BSt 500 rebar

Partial safety factors

1.5 for all stud sizes

1.8 for all rebar sizes