

The high-performance concrete screw for absolute installation ease

High performance steel anchors 4

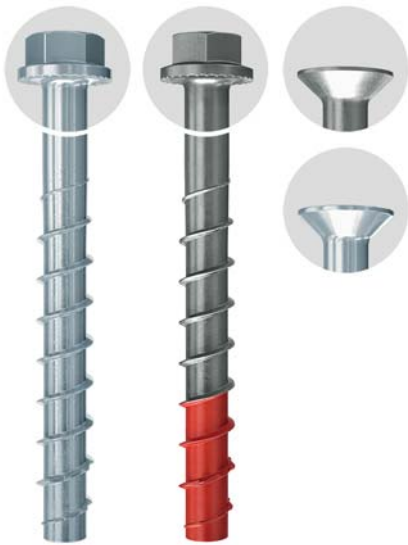

VERSIONS

- Zinc-plated steel
- Stainless steel A4

BUILDING MATERIALS

Approved for:

- Concrete C20/25 to C50/60, cracked and non-cracked

Also suitable for:

- Concrete C12/15
- Solid building materials
- Masonry with a dense structure

CERTIFICATES

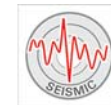

ADVANTAGES

- With up to 3 embedment depths, the ULTRACUT FBS II allows for the same screw to be used for different component thicknesses.
- Unique saw-tooth geometry cuts quickly into the concrete - also in multiple use and reinforced concrete.
- The short ULTRACUT FBS II, with a reduced embedment depth, allows for a short drill hole depth and fast installation which makes it an efficient choice for many applications.
- The performance categories seismic C1 and C2 ensure that the strictest of safety standards and earthquake specifications can be fulfilled.
- For the zinc-plated steel version the checking gauge allows for reuse covered by the approval.
- The specially hardened red tip of the stainless steel A4 version provides faster and more secure installation.
- The stainless steel concrete screw guarantees a high level of corrosion resistance especially for wet conditions and in outdoor areas.

APPLICATIONS

- Guard rails
- Consoles/Base plates
- Metal profiles
- Steel constructions
- Façades
- Protection barriers
- Results/beam anchors
- Shuttering props (only FBS II zinc-plated steel)
- Temporary anchoring, e.g. of building site equipment (only FBS II zinc-plated steel)

FUNCTIONING

- The ULTRACUT FBS II is recommended for the push-through installation.
- Drill holes do not need to be cleaned during vertical installation (ceiling and floor). For floor fixings the hole must be drilled 3x drill hole diameter deeper.
- The approved adjustment for the concrete screws allows the screw to be unscrewed twice for a total length of 20 mm, to place maximum 10 mm packing below the base plates or to align the attached part, and then to tighten the screw again.
- We recommend using a tangential impact screwdriver with a suitable impact screwdriver socket or an internal torx drive.
- The screw is installed correctly when the screw head sits flush on the fixture (visual setting control).

INSTALLATION

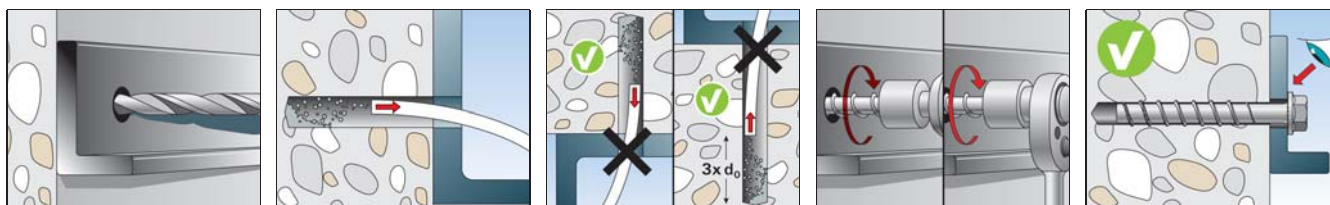

FIXTURE ADJUSTMENT

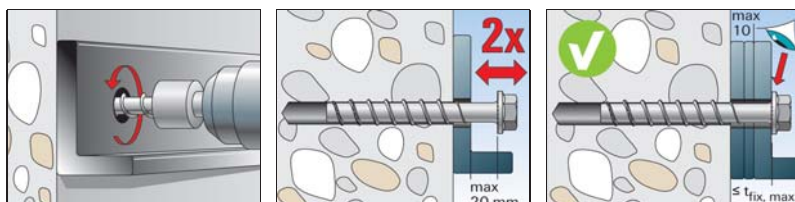

ADDITIONAL FOR SEISMIC

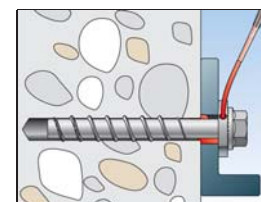

TECHNICAL DATA



ULTRACUT FBS II US - hexagon head with integral washer

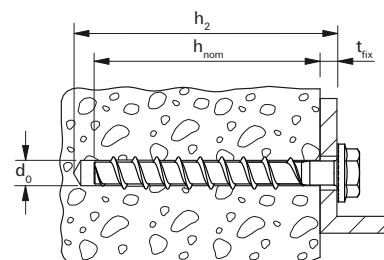

Item	Art.-No.	Approval ETA	Drill hole diameter	Min. drill hole depth for fixings	Screw	Screw-in depth with fixture thickness	Screw-in depth with fixture thickness	Screw-in depth with fixture thickness	Drive	Sales unit
			d_0 [mm]	h_2 [mm]	$d_a \times l_s$ [mm]	h_{nom1} / t_{fix} [mm]	h_{nom2} / t_{fix} [mm]	h_{nom3} / t_{fix} [mm]		[pcs]
ULTRACUT FBS II 8x55 5/- US TX	536851	■	8	65	10 x 55	50 / 5	- / -	- / -	TX40/SW13	50
ULTRACUT FBS II 8x70 20/5 US TX	536852	■	8	80	10 x 70	50 / 20	- / -	65 / 5	TX40/SW13	50
ULTRACUT FBS II 8x80 30/15 US TX	536853	■	8	90	10 x 80	50 / 30	- / -	65 / 15	TX40/SW13	50
ULTRACUT FBS II 8x90 40/25 US TX	536854	■	8	100	10 x 90	50 / 40	- / -	65 / 25	TX40/SW13	50
ULTRACUT FBS II 8x100 50/35 US TX	536855	■	8	110	10 x 100	50 / 50	- / -	65 / 35	TX40/SW13	50
ULTRACUT FBS II 8x110 60/45 US TX	536856	■	8	120	10 x 110	50 / 60	- / -	65 / 45	TX40/SW13	50
ULTRACUT FBS II 8x130 80/65 US TX	536857	■	8	140	10 x 130	50 / 80	- / -	65 / 65	TX40/SW13	50
ULTRACUT FBS II 10x60 5/-/- US	536858	■	10	70	12 x 60	55 / 5	- / -	- / -	SW 15	50
ULTRACUT FBS II 10x70 15/5/- US	536859	■	10	80	12 x 70	55 / 15	65 / 5	- / -	SW 15	50
ULTRACUT FBS II 10x80 25/15/- US	536860	■	10	90	12 x 80	55 / 25	65 / 15	- / -	SW 15	50
ULTRACUT FBS II 10x90 35/25/5 US	536861	■	10	100	12 x 90	55 / 35	65 / 25	85 / 5	SW 15	50
ULTRACUT FBS II 10x100 45/35/15 US	536862	■	10	110	12 x 100	55 / 45	65 / 35	85 / 15	SW 15	50
ULTRACUT FBS II 10x120 65/55/35 US	536863	■	10	130	12 x 120	55 / 65	65 / 55	85 / 35	SW 15	50
ULTRACUT FBS II 10x140 85/75/55 US	536864	■	10	150	12 x 140	55 / 85	65 / 75	85 / 55	SW 15	50
ULTRACUT FBS II 10x160 105/95/75 US	536865	■	10	170	12 x 160	55 / 105	65 / 95	85 / 75	SW 15	50
ULTRACUT FBS II 10x200 145/135/115 US	536866	■	10	210	12 x 200	55 / 145	65 / 135	85 / 115	SW 15	20
ULTRACUT FBS II 10x230 175/165/145 US	536867	■	10	240	12 x 230	55 / 175	65 / 165	85 / 145	SW 15	20
ULTRACUT FBS II 10x260 205/195/175 US	536868	■	10	270	12 x 260	55 / 205	65 / 195	85 / 175	SW 15	20
ULTRACUT FBS II 12x70 10/-/- US	536869	■	12	80	14 x 70	60 / 10	- / -	- / -	SW 17	20
ULTRACUT FBS II 12x85 25/10/- US	536870	■	12	95	14 x 85	60 / 25	75 / 10	- / -	SW 17	20
ULTRACUT FBS II 12x110 50/35/10 US	536871	■	12	120	14 x 110	60 / 50	75 / 35	100 / 10	SW 17	20
ULTRACUT FBS II 12x130 70/55/30 US	536872	■	12	140	14 x 130	60 / 70	75 / 55	100 / 30	SW 17	20
ULTRACUT FBS II 12x150 90/75/50 US	536873	■	12	160	14 x 150	60 / 90	75 / 75	100 / 50	SW 17	20
ULTRACUT FBS II 14x75 10/-/- US	536874	■	14	90	16 x 75	65 / 10	- / -	- / -	SW 21	20
ULTRACUT FBS II 14x95 30/10/- US	536875	■	14	110	16 x 95	65 / 30	85 / 10	- / -	SW 21	20
ULTRACUT FBS II 14x100 35/15/- US	536876	■	14	115	16 x 100	65 / 35	85 / 15	- / -	SW 21	20
ULTRACUT FBS II 14x125 60/40/10 US	536877	■	14	140	16 x 125	65 / 60	85 / 40	115 / 10	SW 21	10
ULTRACUT FBS II 14x150 85/65/35 US	536878	■	14	165	16 x 150	65 / 85	85 / 65	115 / 35	SW 21	10

TECHNICAL DATA



ULTRACUT FBS II SK - countersunk head

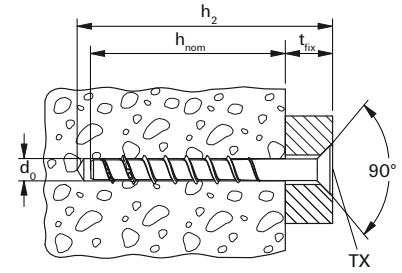

4 High performance steel anchors

Item	Art.-No.	Approval ETA	Drill hole diameter	Min. drill hole depth for through fixings	Screw	Screw-in depth with fixture thickness	Screw-in depth with fixture thickness	Screw-in depth with fixture thickness	Drive	Sales unit
			d_0 [mm]	h_2 [mm]	$d_a \times l_s$ [mm]	h_{nom1} / t_{fix} [mm]	h_{nom2} / t_{fix} [mm]	h_{nom3} / t_{fix} [mm]		
ULTRACUT FBS II 8x60 10/- SK	536880	■	8	70	10 x 60	50 / 10	- / -	- / -	TX40	50
ULTRACUT FBS II 8x80 30/15 SK	536881	■	8	90	10 x 80	50 / 30	- / -	65 / 15	TX40	50
ULTRACUT FBS II 8x90 40/25 SK	536882	■	8	100	10 x 90	50 / 40	- / -	65 / 25	TX40	50
ULTRACUT FBS II 10x65 10/-/- SK	536884	■	10	75	12 x 65	55 / 10	- / -	- / -	TX50	50
ULTRACUT FBS II 10x80 25/15/- SK	536885	■	10	90	12 x 80	55 / 25	65 / 15	- / -	TX50	50
ULTRACUT FBS II 10x95 40/30/10 SK	536886	■	10	105	12 x 95	55 / 40	65 / 30	85 / 10	TX50	50
ULTRACUT FBS II 10x100 45/35/15 SK	536887	■	10	110	12 x 100	55 / 45	65 / 35	85 / 15	TX50	50
ULTRACUT FBS II 10x120 65/55/35 SK	536888	■	10	130	12 x 120	55 / 65	65 / 55	85 / 35	TX50	50

TECHNICAL DATA



ULTRACUT FBS II US A4 - hexagon head with molded washer, stainless steel A4



ULTRACUT FBS II SK A4 - countersunk head, stainless steel A4

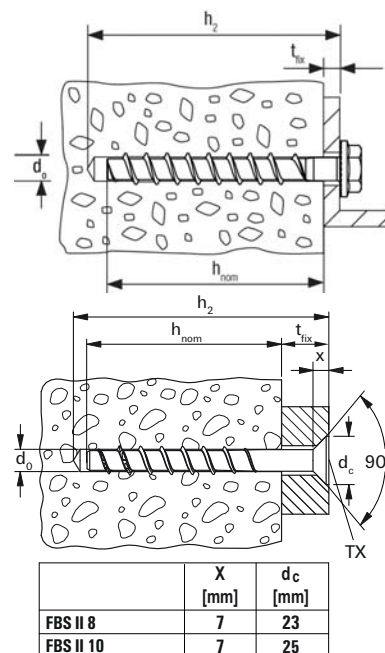

Item	Art.-No.	Approval ETA	Drill hole diameter	Min. drill hole depth for through fixings	Screw length	Screw-in depth with fixture thickness	Screw-in depth with fixture thickness	Screw-in depth with fixture thickness	Drive	Sales unit [pcs]
			d ₀ [mm]	h ₂ [mm]	l _s [mm]	h _{nom1} / t _{fix} [mm]	h _{nom3} / t _{fix} [mm]	h _{nom2} / t _{fix} [mm]		
A4										
FBS II 8 x 60 10/- US A4	543565	■	8	70	60	50 / 10	- / -	- / -	SW 13	50
FBS II 8 x 70 5/- US A4	543566	■	8	80	70	50 / 20	65 / 5	- / -	SW 13	50
FBS II 8 x 80 15/- US A4	543567	■	8	90	80	50 / 30	65 / 15	- / -	SW 13	50
FBS II 8 x 90 25/- US A4	543568	■	8	100	90	50 / 40	65 / 25	- / -	SW 13	50
FBS II 10 x 60 5/-/- US A4	543569	■	10	70	60	55 / 5	- / -	- / -	SW 15	50
FBS II 10 x 70 15/5/- US A4	543570	■	10	80	70	55 / 15	- / -	65 / 5	SW 15	50
FBS II 10 x 80 25/15/- US A4	543571	■	10	90	80	55 / 25	- / -	65 / 15	SW 15	50
FBS II 10 x 90 5/- US A4	543572	■	10	100	90	55 / 35	85 / 5	65 / 25	SW 15	50
FBS II 10 x 100 15/- US A4	543573	■	10	110	100	55 / 45	85 / 15	65 / 35	SW 15	50
FBS II 10 x 120 35/- US A4	543574	■	10	130	120	55 / 65	85 / 35	65 / 55	SW 15	50
FBS II 12 x 70 10/-/- US A4	543575	■	12	80	70	60 / 10	- / -	- / -	SW 17	20
FBS II 12 x 85 25/10/- US A4	543576	■	12	95	85	60 / 25	- / -	75 / 10	SW 17	20
FBS II 12 x 110 10/- US A4	543577	■	12	120	110	60 / 50	100 / 10	75 / 35	SW 17	50
FBS II 12 x 130 30/- US A4	543578	■	12	140	130	60 / 70	100 / 30	75 / 55	SW 17	20
FBS II 8 x 60 10/- SK A4	543579	■	8	70	60	50 / 10	- / -	- / -	TX40	50
FBS II 8 x 80 15/- SK A4	543580	■	8	90	80	50 / 30	65 / 15	- / -	TX40	50
FBS II 8 x 90 25/- SK A4	543581	■	8	100	90	50 / 40	65 / 25	- / -	TX40	50
FBS II 10 x 65 10/-/- SK A4	543582	■	10	75	65	55 / 10	- / -	- / -	TX50	50
FBS II 10 x 80 25/15/- SK A4	543583	■	10	90	80	55 / 25	- / -	65 / 15	TX50	50
FBS II 10 x 95 10/- SK A4	543584	■	10	105	95	55 / 40	85 / 10	65 / 30	TX50	50
FBS II 10 x 100 15/- SK A4	543585	■	10	110	100	55 / 45	85 / 15	65 / 35	TX50	50
FBS II 10 x 120 35/- SK A4	543586	■	10	130	120	55 / 65	85 / 35	65 / 55	TX50	50

ACCESSORIES



Checking gauge FUP



Nut SW



Nut TX



FMB T40 Maxx Bit



Profi-bit FPB T50 5/16"

Item	Art.-No.	Internal diameter	Drive	Match	Sales unit [pcs]
		D [mm]			
Checking gauge FUP 8	537200	9,9	–	FBS II 8	1
Checking gauge FUP 10	537201	12,0	–	FBS II 10	1
Checking gauge FUP 12	537202	13,0	–	FBS II 12	1
Checking gauge FUP 14	537203	15,0	–	FBS II 14	1
Nut SW13	538578	–	1/2" / SW13	FBS II 8	1
Nut SW15	538579	–	1/2" / SW15	FBS II 10	1
Nut SW17	538580	–	1/2" / SW17	FBS II 12	1
Nut SW21	538581	–	1/2" / SW21	FBS II 14	1
Nut TX40	538575 1)	–	1/2" - 1/4"	FBS II 8 / FBS II 8 SK	1
Nut TX50	538576 2)	–	1/2" - 5/16"	FBS II 10 / FBS II 10 SK	1
FMB T40 Maxx Bit W 5	533159	–	TX40	FBS II 8 / FBS II 8 SK	10
FPB Profi-Bit T50 5/16"	538574	–	TX50	FBS II 10 SK	1

1) Suitable for FMB T40 Maxx Bit

2) Suitable for FPB Profi-Bit T50 5/16"

ACCESSORIES



Filling washer FFD



Washer U

Item	Art.-No.	Internal diameter	External-Ø	Match	Sales unit [pcs]
		D [mm]	d [mm]		
FFD 22 x 9 x 6	547515	9,0	22	FBS II 6	4
FFD 26 x 12 x 6	538458	12,0	26	FBS II 8	4
FFD 30 x 14 x 6	538459	14,2	30	FBS II 10 / FBS II 12	4
FFD 38 x 19 x 7	538460	19,2	38	FBS II 14	4
FFD 30x14x6 A4	541987	14,0	30	FBS II 10 A4 / FBS II 12 A4	4
Washer for FBS 10	520471	13,5	44	FBS II 10	50

INSTALLATION DATA - CONCRETE C20/25 - C50/60

Type US

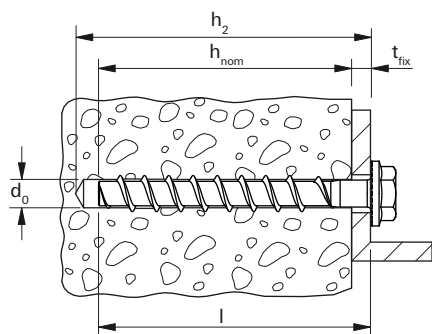

Type SK

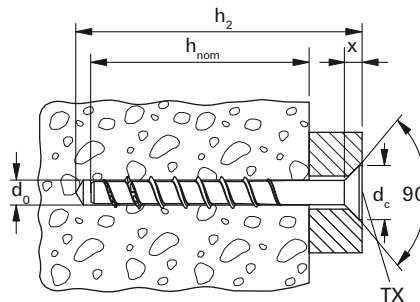

	X [mm]	dc [mm]
ULTRACUT FBS II 8	6	20
ULTRACUT FBS II 10	7	23

Concrete screw ULTRACUT FBS II 8-14			8	10	12	14
Drill hole diameter	d0	[mm]	8	10	12	14
Nominal screw-in depth	hnom1	[mm]	50	55	60	65
	hnom2	[mm]	-	65	75	85
	hnom3	[mm]	65	85	100	115
Drill hole depth (push-through installation)	h2 ≥	[mm]	l + 10	l + 10	l + 10	l + 15
Clearance hole diameter	df		10,6 - 12	12,8 - 14	14,8 - 16	16,9 - 18
Max. torque for installation with impact screw driver in concrete	T _{imp, max}		600	650	650	650
Width across flat	SW		13	15	17	21
Drive	Torx		T40 (SK a. US)	T50 (SK)	-	-

INSTALLATION DATA - MASONRY

Concrete screw ULTRACUT FBS II 8-14					
Building material	Compressive strength class [N/mm ²]	Size	[mm]	8	10
		hnom	[mm]	65	85
Solid clay brick (EN771-1)	≥ 12	T _{inst}	[Nm]	10	10
Solid sand-lime brick (EN771-2)	≥ 12	T _{inst}	[Nm]	15	15
Aerated concrete (EN771-4)	≥ 6	T _{inst}	[Nm]	5	5

INSTALLATION OF CONCRETE SCREWS (USE A CORDLESS OR CABLED IMPACT WRENCH)

Concrete screw ULTRACUT FBS II 8-14	Maximum torque gvz [Nm]	Maximum torque A4 [Nm]
FBS II 8	600	450
FBS II 10	650	450
FBS II 12	650	650
FBS II 14	650	-

*1 The values apply to concrete strength of approx. 40N/mm², for other concrete strength classes the values may differ.
The conversion of nominal output into effective tightening torque varies from machine to machine - always therefore use torque control.

LOADS

Concrete screw ULTRACUT FBS II

zinc plated steel

Permissible loads of a single anchor in cracked normal concrete (concrete tension zone) of strength class C20/25 (~B25) ^{1) 2) 3) 10)}											Minimum spacings while reducing the load	
Type	Material fixing element	Minimum member thickness	Screw-in depth	Maximum installation torque	Installation torque	Permissible tensile load	Permissible shear load	Required edge distance (with one edge) for		Required spacing for	Min. spacing	Min. edge distance
								Max. tension load c	Max. shear load c			
		h_{min} [mm]	h_{nom} [mm]	T_{max} [Nm]	$T_{imp,max}^{6)}$ [Nm]	$N_{perm}^{7)}$ [kN]	$V_{perm}^{7)}$ [kN]	c [mm]	c [mm]	Max. Load s_{cr} [mm]	$s_{min}^{8)}$ [mm]	$c_{min}^{8)}$ [mm]
FBS II 6x40 ⁵⁾	gvz	80	40	10	450	1,2	4,3	35	110	100	35	35
FBS II 6x45 ⁵⁾	gvz	90	45	10	450	1,7	4,3	35	105	110	35	35
FBS II 6x50 ⁵⁾	gvz	90	50	10	450	1,9	4,3	35	100	120	35	35
FBS II 6x55 ⁵⁾	gvz	100	55	10	450	2,4	6,3	35	145	135	35	35
FBS II 8x50	gvz	100	50	0	600	2,9	4,3	35	90	120	35	35
FBS II 8x65	gvz	120	65	0	600	5,7	9,0	70	180	160	35	35
FBS II 10x55	gvz	100	55	0	650	4,3	4,8	55	100	130	40	40
FBS II 10x65	gvz	120	65	0	650	5,7	12,5	70	250	155	40	40
FBS II 10x85	gvz	140	85	0	650	9,6	16,6	105	305	205	40	40
FBS II 12x60	gvz	110	60	0	650	5,5	11,0	70	230	145	50	50
FBS II 12x75	gvz	130	75	0	650	8,0	15,2	90	290	180	50	50
FBS II 12x100	gvz	150	100	0	650	12,5	20,3	125	355	245	50	50
FBS II 14x65	gvz	120	65	0	650	6,1	12,1	75	235	150	60	60
FBS II 14x85	gvz	140	85	0	650	9,4	18,8	100	340	205	60	60
FBS II 14x115	gvz	180	115	0	650	15,4	29,4	140	465	280	60	60

For the design the complete assessment ETA-15/0352 has to be considered.⁹⁾

¹⁾ The partial safety factors for material resistance as regulated in the ETA-15/0352 as well as a partial safety factor for load actions of $\gamma_L = 1,4$ are considered. As an single anchor counts e.g. an anchor with a spacing $s \geq 3 \cdot h_{ef}$ and an edge distance $c \geq 1,5 \cdot h_{ef}$. Accurate data see ETA-15/0352.

²⁾ For higher concrete strength classes up to C50/60 higher permissible loads may be possible.

³⁾ Drill method hammer drilling resp. hollow drilling. For further allowable drill methods see ETA-15/0352.

⁴⁾ The anchorage depths smaller than 40 mm are only allowed for single anchors as part of a multiple fixing of non-structural systems.

⁵⁾ Diamond drilling not permitted.

⁶⁾ Maximum allowable torque for installation with any tangential impact screw driver.

⁷⁾ For combinations of tensile loads and shear loads or for shear loads with lever arm (bending moments) as well as reduced edge distances or spacings (anchor groups) we recommend to use our anchor design software C-FIX.

⁸⁾ Minimum possible axial spacings resp. edge distance while reducing the permissible load.

⁹⁾ The given loads refer to the European Technical Assessment ETA-15/0352, issue date 30/10/2018. Design of the loads according ETAG 001, Annex C, Method A (for static resp. quasi-static loads).

¹⁰⁾ A reinforcement in the concrete to prevent splitting is required. The width of the cracks has to be limited under consideration of the splitting forces at $w_k \sim 0,3$ mm.

LOADS

Concrete screw ULTRACUT FBS II

zinc plated steel

Permissible loads of a single anchor in non-cracked normal concrete (concrete compression zone) of strength class C20/25 (~B25) ^{1) 2) 3)}											Minimum spacings while reducing the load	
Type	Material fixing element	Minimum member thickness	Screw-in depth	Maximum installation torque	Installation torque	Permissible tensile load	Permissible shear load	Required edge distance (with one edge) for		Required spacing for	Min. spacing	Min. edge distance
								Max. tension load c	Max. shear load c			
		h_{min} [mm]	h_{nom} [mm]	T_{max} [Nm]	$T_{imp,max}^{6)}$ [Nm]	$N_{perm}^{7)}$ [kN]	$V_{perm}^{7)}$ [kN]	c [mm]	c [mm]	Max. Load s_{cr} [mm]	$s_{min}^{8)}$ [mm]	$c_{min}^{8)}$ [mm]
FBS II 6x40 ⁵⁾	gvz	80	40	10	450	3,8	4,3	40	75	100	35	35
FBS II 6x45 ⁵⁾	gvz	90	45	10	450	4,8	4,3	50	70	110	35	35
FBS II 6x50 ⁵⁾	gvz	90	50	10	450	5,7	4,3	55	70	120	35	35
FBS II 6x55 ⁵⁾	gvz	100	55	10	450	6,4	6,3	60	100	135	35	35
FBS II 8x50	gvz	100	50	0	600	6,1	6,1	60	90	120	35	35
FBS II 8x65	gvz	120	65	0	600	9,0	9,0	80	125	160	35	35
FBS II 10x55	gvz	100	55	0	650	6,8	6,8	65	100	130	40	40
FBS II 10x65	gvz	120	65	0	650	8,8	14,0	80	195	155	40	40
FBS II 10x85	gvz	140	85	0	650	13,5	16,6	105	210	205	40	40
FBS II 12x60	gvz	110	60	0	650	7,7	15,2	70	220	145	50	50
FBS II 12x75	gvz	130	75	0	650	11,2	15,2	90	195	180	50	50
FBS II 12x100	gvz	150	100	0	650	17,5	20,3	125	240	245	50	50

LOADS

Concrete screw ULTRACUT FBS II

zinc plated steel

Permissible loads of a single anchor in non-cracked normal concrete (concrete compression zone) of strength class C20/25 (~B25) ^{1) 2) 3)}											Minimum spacings while reducing the load	
Type	Material fixing element	Minimum member thickness h_{min} [mm]	Screw-in depth h_{nom} [mm]	Maximum installation torque T_{max} [Nm]	Installation torque $T_{imp,max}^6)$ [Nm]	Permissible tensile load $N_{perm}^7)$ [kN]	Permissible shear load $V_{perm}^7)$ [kN]	Required edge distance (with one edge) for		Required spacing for Max. Load s_{cr} [mm]	Min. spacing $s_{min}^8)$ [mm]	Min. edge distance $c_{min}^8)$ [mm]
								Max. tension load c [mm]	Max. shear load c [mm]			
FBS II 14x65	gvz	120	65	0	650	8,5	17,0	75	235	150	60	60
FBS II 14x85	gvz	140	85	0	650	13,2	22,1	100	275	205	60	60
FBS II 14x115	gvz	180	115	0	650	21,6	29,4	140	315	280	60	60

For the design the complete assessment ETA-15/0352 has to be considered.⁹⁾

- ¹⁾ The partial safety factors for material resistance as regulated in the ETA-15/0352 as well as a partial safety factor for load actions of $\gamma_L = 1,4$ are considered. As an single anchor counts e.g. an anchor with a spacing $s \geq 3 \cdot h_{ef}$ and an edge distance $c \geq 1,5 \cdot h_{ef}$. Accurate data see ETA-15/0352.
- ²⁾ For higher concrete strength classes up to C50/60 higher permissible loads may be possible.
- ³⁾ Drill method hammer drilling resp. hollow drilling. For further allowable drill methods see ETA-15/0352.
- ⁴⁾ The anchorage depths smaller than 40 mm are only allowed for single anchors as part of a multiple fixing of non-structural systems.
- ⁵⁾ Diamond drilling not permitted.
- ⁶⁾ Maximum allowable torque for installation with any tangential impact screw driver.
- ⁷⁾ For combinations of tensile loads and shear loads or for shear loads with lever arm (bending moments) as well as reduced edge distances or spacings (anchor groups) we recommend to use our anchor design software C-FIX.
- ⁸⁾ Minimum possible axial spacings resp. edge distance while reducing the permissible load.
- ⁹⁾ The given loads refer to the European Technical Assessment ETA-15/0352, issue date 30/10/2018. Design of the loads according ETAG 001, Annex C, Method A (for static resp. quasi-static loads).

LOADS

Concrete screw with hexagon head and washer ULTRACUT FBS II A4 US

stainless steel

Permissible loads of a single anchor in cracked normal concrete (concrete tension zone) of strength class C20/25 (~B25) ^{1) 2) 3) 8)}											Minimum spacings while reducing the load	
Type	Material fixing element	Minimum member thickness h_{min} [mm]	Screw-in depth h_{nom} [mm]	Installation torque $T_{imp,max}^4)$ [Nm]	Permissible tensile load $N_{perm}^5)$ [kN]	Permissible shear load $V_{perm}^5)$ [kN]	Required edge distance (with one edge) for		Required spacing for Max. Load s_{cr} [mm]	Min. spacing $s_{min}^6)$ [mm]	Min. edge distance $c_{min}^6)$ [mm]	
							Max. tension load c [mm]	Max. shear load c [mm]				
FBS II 8x50	A4	100	50	450	1,9	4,3	35	90	120	35	35	
FBS II 8x65	A4	120	65	450	4,3	6,4	45	125	160	35	35	
FBS II 10x55	A4	100	55	450	2,1	4,8	40	100	130	40	40	
FBS II 10x65	A4	120	65	450	2,9	6,2	40	115	155	40	40	
FBS II 10x85	A4	140	85	450	7,6	19,2	75	360	205	40	40	
FBS II 12x60	A4	110	60	650	2,1	5,5	50	105	145	50	50	
FBS II 12x75	A4	130	75	650	5,2	15,9	50	305	180	50	50	
FBS II 12x100	A4	150	100	650	12,5	25,0	125	445	245	50	50	

For the design the complete assessment ETA-17/0740 has to be considered.⁷⁾

- ¹⁾ The partial safety factors for material resistance as regulated in the ETA-17/0740 as well as a partial safety factor for load actions of $\gamma_F = 1,4$ are considered. As an single anchor counts e.g. an anchor with a spacing $s \geq 3 \cdot h_{ef}$ and an edge distance $c \geq 1,5 \cdot h_{ef}$. Accurate data see ETA-17/0740.
- ²⁾ For higher concrete strength classes up to C50/60 higher permissible loads may be possible.
- ³⁾ Drill method Hammer drilling resp. hollow drilling. For further allowable drill methods see ETA-17/0740.
- ⁴⁾ Maximum allowable torque for installation with any tangential impact screw driver.
- ⁵⁾ For combinations of tensile loads and shear loads or for shear loads with lever arm (bending moments) as well as reduced edge distances or spacings (anchor groups) we recommend to use our anchor design software C-FIX.
- ⁶⁾ Minimum possible axial spacings resp. edge distance while reducing the permissible load.
- ⁷⁾ The given loads refer to the European Technical Assessment ETA-17/0740, issue date 23/10/2018. Design of the loads according TR055/ETAG 001, Annex C, Method A (for static resp. quasi-static loads).
- ⁸⁾ A reinforcement in the concrete to prevent splitting is required. The width of the cracks has to be limited under consideration of the splitting forces at $w_k \sim 0,3$ mm.

LOADS

Concrete screw with hexagon head and washer ULTRACUT FBS II A4 US

stainless steel

Permissible loads of a single anchor in non-cracked normal concrete (concrete compression zone) of strength class C20/25 (~B25) ^{1) 2) 3)}										Minimum spacings while reducing the load	
Type	Material fixing element	Minimum member thickness	Screw-in depth	Installation torque	Permissible tensile load	Permissible shear load	Required edge distance (with one edge) for		Required spacing for	Min. spacing	Min. edge distance
							Max. tension load c	Max. shear load c			
		h_{min} [mm]	h_{nom} [mm]	$T_{imp,max}^{4)}$ [Nm]	$N_{perm}^{5)}$ [kN]	$V_{perm}^{5)}$ [kN]	[mm]	[mm]	Max. Load s_{cr} [mm]	$s_{min}^{6)}$ [mm]	$c_{min}^{6)}$ [mm]
FBS II 8x50	A4	100	50	450	3,3	6,1	35	90	120	35	35
FBS II 8x65	A4	120	65	450	6,7	9,0	55	120	160	35	35
FBS II 10x55	A4	100	55	450	4,0	6,8	40	100	130	40	40
FBS II 10x65	A4	120	65	450	6,7	8,8	55	115	155	40	40
FBS II 10x85	A4	140	85	450	13,5	20,9	105	270	205	40	40
FBS II 12x60	A4	110	60	650	4,8	7,7	50	105	145	50	50
FBS II 12x75	A4	130	75	650	5,7	22,4	50	300	180	50	50
FBS II 12x100	A4	150	100	650	17,5	26,2	125	320	245	50	50

For the design the complete assessment ETA-17/0740 has to be considered.⁷⁾

¹⁾ The partial safety factors for material resistance as regulated in the ETA-17/0740 as well as a partial safety factor for load actions of $\gamma_F = 1,4$ are considered. As an single anchor counts e.g. an anchor with a spacing $s \geq 3 \cdot h_{ef}$ and an edge distance $c \geq 1,5 \cdot h_{ef}$. Accurate data see ETA-17/0740.

²⁾ For higher concrete strength classes up to C50/60 higher permissible loads may be possible.

³⁾ Drill method Hammer drilling resp. hollow drilling. For further allowable drill methods see ETA-17/0740.

⁴⁾ Maximum allowable torque for installation with any tangential impact screw driver.

⁵⁾ For combinations of tensile loads and shear loads or for shear loads with lever arm (bending moments) as well as reduced edge distances or spacings (anchor groups) we recommend to use our anchor design software C-FIX.

⁶⁾ Minimum possible axial spacings resp. edge distance while reducing the permissible load.

⁷⁾ The given loads refer to the European Technical Assessment ETA-17/0740, issue date 23/10/2018. Design of the loads according TR055/ETAG 001, Annex C, Method A (for static resp. quasi-static loads).

LOADS

Concrete screw with countersunk head ULTRACUT FBS II A4 SK

stainless steel

Permissible loads of a single anchor in cracked normal concrete (concrete tension zone) of strength class C20/25 (~B25) ^{1) 2) 3) 8)}										Minimum spacings while reducing the load	
Type	Material fixing element	Minimum member thickness	Screw-in depth	Installation torque	Permissible tensile load	Permissible shear load	Required edge distance (with one edge) for		Required spacing for	Min. spacing	Min. edge distance
							Max. tension load c	Max. shear load c			
		h_{min} [mm]	h_{nom} [mm]	$T_{imp,max}^{4)}$ [Nm]	$N_{perm}^{5)}$ [kN]	$V_{perm}^{5)}$ [kN]	[mm]	[mm]	Max. Load s_{cr} [mm]	$s_{min}^{6)}$ [mm]	$c_{min}^{6)}$ [mm]
FBS II 8x50	A4	100	50	450	1,9	4,3	35	90	120	35	35
FBS II 8x65	A4	120	65	450	4,3	6,4	45	125	160	35	35
FBS II 10x55	A4	100	55	450	2,1	4,8	40	100	130	40	40
FBS II 10x65	A4	120	65	450	2,9	6,2	40	115	155	40	40
FBS II 10x85	A4	140	85	450	7,6	19,2	75	360	205	40	40

For the design the complete assessment ETA-17/0740 has to be considered.⁷⁾

¹⁾ The partial safety factors for material resistance as regulated in the ETA-17/0740 as well as a partial safety factor for load actions of $\gamma_F = 1,4$ are considered. As an single anchor counts e.g. an anchor with a spacing $s \geq 3 \cdot h_{ef}$ and an edge distance $c \geq 1,5 \cdot h_{ef}$. Accurate data see ETA-17/0740.

²⁾ For higher concrete strength classes up to C50/60 higher permissible loads may be possible.

³⁾ Drill method hammer drilling. For further allowable drill methods see ETA-17/0740.

⁴⁾ Maximum allowable torque for installation with any tangential impact screw driver.

⁵⁾ For combinations of tensile loads and shear loads or for shear loads with lever arm (bending moments) as well as reduced edge distances or spacings (anchor groups) we recommend to use our anchor design software C-FIX.

⁶⁾ Minimum possible axial spacings resp. edge distance while reducing the permissible load.

⁷⁾ The given loads refer to the European Technical Assessment ETA-17/0740, issue date 23/10/2018. Design of the loads according TR055/ETAG 001, Annex C, Method A (for static resp. quasi-static loads).

⁸⁾ A reinforcement in the concrete to prevent splitting is required. The width of the cracks has to be limited under consideration of the splitting forces at $w_k \sim 0,3$ mm.

LOADS

Concrete screw with countersunk head ULTRACUT FBS II A4 SK

stainless steel

Permissible loads of a single anchor in non-cracked normal concrete (concrete compression zone) of strength class C20/25 (~B25) ¹⁾²⁾³⁾										Minimum spacings while reducing the load	
Type	Material fixing element	Minimum member thickness h_{min} [mm]	Screw-in depth h_{nom} [mm]	Installation torque $T_{imp,max}^{4)}$ [Nm]	Permissible tensile load $N_{perm}^{5)}$ [kN]	Permissible shear load $V_{perm}^{5)}$ [kN]	Required edge distance (with one edge) for		Required spacing for Max. Load s_{cr} [mm]	Min. spacing $s_{min}^{6)}$ [mm]	Min. edge distance $c_{min}^{6)}$ [mm]
							Max. tension load c [mm]	Max. shear load c [mm]			
FBS II 8x50	A4	100	50	450	3,3	6,1	35	90	120	35	35
FBS II 8x65	A4	120	65	450	6,7	9,0	55	120	160	35	35
FBS II 10x55	A4	100	55	450	4,0	6,8	40	100	130	40	40
FBS II 10x65	A4	120	65	450	6,7	8,8	55	115	155	40	40
FBS II 10x85	A4	140	85	450	13,5	20,9	105	270	205	40	40

¹⁾ For the design the complete assessment ETA-17/0740 has to be considered. ⁷⁾

²⁾ The partial safety factors for material resistance as regulated in the ETA-17/0740 as well as a partial safety factor for load actions of $\gamma_F = 1,4$ are considered. As an single anchor counts e.g. an anchor with a spacing $s \geq 3 \cdot h_{ef}$ and an edge distance $c \geq 1,5 \cdot h_{ef}$. Accurate data see ETA-17/0740.

³⁾ For higher concrete strength classes up to C50/60 higher permissible loads may be possible.

⁴⁾ Drill method hammer drilling. For further allowable drill methods see ETA-17/0740.

⁵⁾ Maximum allowable torque for installation with any tangential impact screw driver.

⁶⁾ For combinations of tensile loads and shear loads or for shear loads with lever arm (bending moments) as well as reduced edge distances or spacings (anchor groups) we recommend to use our anchor design software C-FIX.

⁷⁾ Minimum possible axial spacings resp. edge distance while reducing the permissible load.

⁸⁾ The given loads refer to the European Technical Assessment ETA-17/0740, issue date 23/10/2018. Design of the loads according TR055/ETAG 001, Annex C, Method A (for static resp. quasi-static loads).

LOADS

Concrete screw ULTRACUT FBS II

Highest recommended loads ¹⁾³⁾ for a single anchor, resp. a fixing point ⁴⁾⁵⁾⁶⁾ in solid brick masonry.

Base material	Compressive strength [N/mm ²]	Type	ULTRACUT		
		Size	FBS II 8	FBS II 10	
		Anchoring depth h_{nom}	[mm]	65	85
Solid clay brick ⁹⁾ (EN771-1) $\geq 240 \times 113 \times 115$ mm	≥ 12	Frec ²⁾³⁾	[kN]	1,1	1,4
	≥ 20	Frec ²⁾³⁾⁷⁾	[kN]	1,6	1,6
Solid sand-lime brick ⁹⁾ (EN771-2) $\geq 240 \times 71 \times 115$ mm	≥ 12	Frec ²⁾³⁾⁷⁾	[kN]	1,2	1,2
	≥ 20	Frec ²⁾³⁾⁷⁾	[kN]	1,2	1,2
Aerated concrete (EN771-4) $\geq 499 \times 249 \times 120$ mm	≥ 6	Frec ²⁾³⁾	[kN]	0,7	0,9
Minimum spacing within anchor groups of 2 or 4 anchors		s_{min}	[mm]	80	
Minimum spacing between single anchors, resp. anchor groups		s_{min}	[mm]	80	
Minimum distance to the horizontal joint		$c_{min,v}^{8)}$	[mm]	20	
Minimum distance to the vertical joint		$c_{min,h}^{8)}$	[mm]	40	
Minimum distance to the free edge		$c_{min,free\ edge}^{8)}$	[mm]	200	
Tightening torque ¹⁰⁾	Solid clay brick ⁹⁾	Tighten	[Nm]	10	
	Solid sandlime brick ⁹⁾			15	
	Aerated concrete			5	

¹⁾ An appropriate safety factor is considered.

²⁾ The given loads apply to the given brick measures for masonry with superimposed load. Bigger brick sizes are minimum equal in case of the loads.

³⁾ The loads only apply to multiple fixings of non-load-bearing systems and are valid for tensile load, shear load and oblique load under any angle.

⁴⁾ On-site screw testing is recommended to validate technical data. If the joints are not visible 100% anchor testing is recommended due to the screws are only working in the bricks and not in the mortar joints.

⁵⁾ A fixing point can be a single anchor, 2 anchors or 4 anchors with a minimum spacing s_{min} . Anchor groups of 4 anchors are arranged in rectangular disposition.

⁶⁾ The fixing points have to be arranged in this way that there will be always maximum one fixing point arranged in one brick.

⁷⁾ Brick pull-out is decisive.

⁸⁾ The values $c_{min,v}$ and $c_{min,h}$ are only valid if the mortar joints are filled proper. Otherwise the joints has to be considered as free edges and $c_{min,free}$ is decisive. Minimum mortar strenght is M2.5

⁹⁾ The values are valid for unperforated solid bricks.

¹⁰⁾ The screw is screwed in with a cordless screwdriver, an impact screwdriver or by hand. The screwing process must be finished immediately when the screw head is in contact with the assembled object. The specified tightening torque must then be applied with a torque wrench.