

The efficient with short expansion element

5 Frame fixings / Stand-off installation

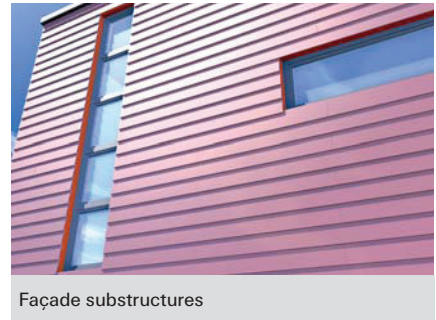

VERSIONS

- Zinc-plated steel
- Stainless steel
- Hot-dip galvanised steel

BUILDING MATERIALS

- Approved for:**
- Concrete \geq C12/15
 - Vertically perforated brick
 - Hollow blocks made from lightweight concrete
 - Perforated sand-lime brick
 - Solid sand-lime brick
 - Aerated concrete
 - Solid block made from lightweight and normal weight concrete
 - Solid brick
 - Thermal insulation blocks
- Also suitable for:**
- Natural stone with dense structure
 - Solid panel made from gypsum

CERTIFICATES



ADVANTAGES

- The special functioning allows for use in solid and hollow building materials with an anchorage depth of just 50 mm, ensuring an economical fixing.
- The ETA assessment covers use in a range of solid and hollow building materials, and guarantees a secure fixing.
- The specially developed combination of plugs and screws ensures the very best handling. The plug has a noticeable hold, making installation more convenient.
- The extensive range with diameters of 6, 8 and 10 mm, usable lengths up to 210 mm.

APPLICATIONS

- Façade, ceiling and roof substructures made of wood and metal
- Windows
- Gates and doors
- Wardrobes
- Kitchen hanging cabinets
- Squared timbers
- Beams
- TV consoles
- Wall covering
- Metal brackets
- Metal supports
- Cable ducts
- Cable trays

FUNCTIONING

- The SXR is suitable for push-through installation.
- The SXR expands in solid building materials. In hollow building materials the loads are transmitted to the substrate webs.
- With vertically perforated bricks, only use rotary drilling (no impact drilling).
- SXR-T with countersunk head screw is recommended for the installation of timber constructions; in the case of metal constructions, use SXR-FUS with a wide sleeve rim and a moulded washer on the screw, which also features an integrated hexagon socket.

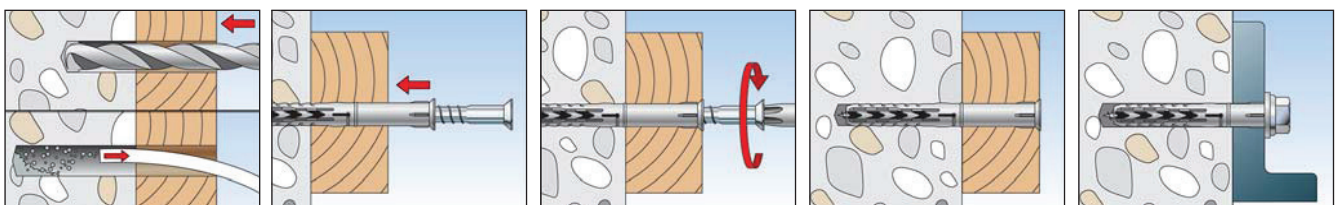

TECHNICAL DATA



SXR - without screw

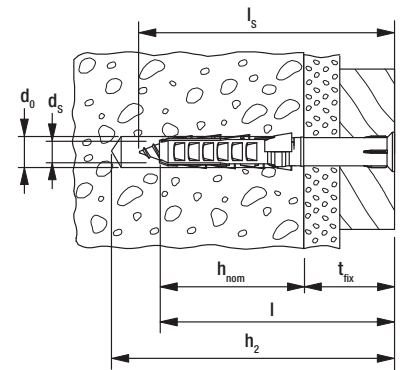

Item	Art.-No.	Drill hole diameter d_0 [mm]	Min. drill hole depth for through fixings h_2 [mm]	Min. anchorage depth h_{nom} [mm]	Anchor length l [mm]	Screw diameter d_s [mm]	Min. screw length l_s [mm]	Max. fixture thickness t_{fix} [mm]	Sales unit [pcs]
SXR 6 x 35	503228	6	45	30	35	4,5	40	5	100
SXR 6 x 50	503229	6	60	30	50	4,5	55	20	100
SXR 6 x 60	503230	6	70	30	60	4,5	65	30	100
SXR 8 x 60	506194	8	70	50	60	5,5 - 6,0	65	10	100
SXR 8 x 80	506196	8	90	50	80	5,5 - 6,0	85	30	100
SXR 8 x 100	506198	8	110	50	100	5,5 - 6,0	125	50	100
SXR 8 x 120	506199	8	130	50	120	5,5 - 6,0	105	70	100

TECHNICAL DATA



SXR-Z - with zinc-plated countersunk head screw with cross drive PZ

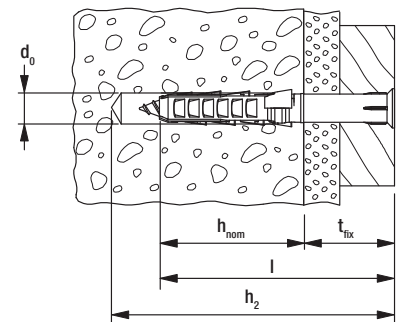

Item	Art.-No.	Drill hole diameter d_0 [mm]	Min. drill hole depth for through fixings h_2 [mm]	Min. anchorage depth h_{nom} [mm]	Anchor length l [mm]	Max. fixture thickness t_{fix} [mm]	Drive	Sales unit [pcs]
SXR 6 x 60 Z	503233 ¹⁾	6	70	30	60	30	PZ2	50

1) not pre-assembled

TECHNICAL DATA



SXR-T - with fischer countersunk head safety screw

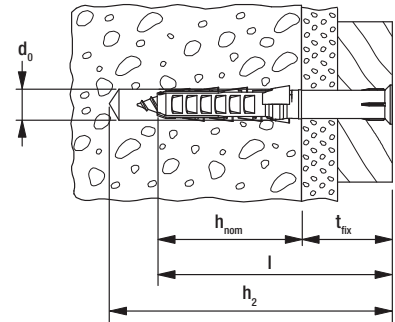

	Zinc-plated steel	Stainless steel	Hot-dip galvanised steel	Approval	Drill hole diameter	Min. drill hole depth for through fixings	Min. anchorage depth	Anchor length	Max. fixture thickness	Drive	Sales unit
	Art.-No.	Art.-No.	Art.-No.	ETA	d_0 [mm]	h_2 [mm]	h_{nom} [mm]	l [mm]	t_{fix} [mm]		[pcs]
Item	gvz	A4	hdg								
SXR 8 x 60 T	502999	—	—	■	8	70	50	60	10	T30	50
SXR 8 x 80 T	503000	—	—	■	8	90	50	80	30	T30	50
SXR 8 x 100 T	503001	—	—	■	8	110	50	100	50	T30	50
SXR 8 x 120 T	503002	—	—	■	8	130	50	120	70	T30	50
SXR 10 x 80 T	046263	046272	—	■	10	90	50	80	30	T40	50
SXR 10 x 100 T	046264	046274	—	■	10	110	50	100	50	T40	50
SXR 10 x 100 T	—	—	509534	—	10	110	50	100	50	T40	50
SXR 10 x 120 T	046265	046278	—	■	10	130	50	120	70	T40	50
SXR 10 x 120 T	—	—	509535	—	10	130	50	120	70	T40	50
SXR 10 x 140 T	046266	046279	—	■	10	150	50	140	90	T40	50
SXR 10 x 140 T	—	—	509536	—	10	150	50	140	90	T40	50
SXR 10 x 160 T	046267	046283	—	■	10	170	50	160	110	T40	50
SXR 10 x 180 T	046268	046285	—	■	10	190	50	180	130	T40	50
SXR 10 x 200 T	046269	046286	—	■	10	210	50	200	150	T40	50
SXR 10 x 230 T	046270	046287	—	■	10	240	50	230	180	T40	50
SXR 10 x 260 T	046271	046288	—	■	10	270	50	260	210	T40	50

TECHNICAL DATA



SXR-FUS - with fischer hexagon head safety screw, moulded washer and integrated T40 bit recess

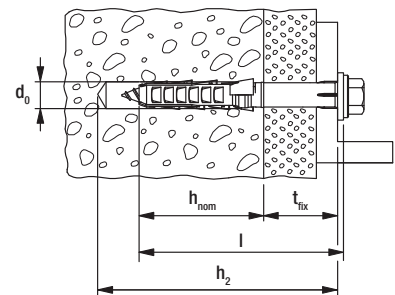

	Zinc-plated steel	Stainless steel	Hot-dip galvanised steel	Approval	Drill hole diameter	Min. drill hole depth for through fixings	Min. anchorage depth	Anchor length	Max. fixture thickness	Drive	Sales unit
	Art.-No.	Art.-No.	Art.-No.	ETA	d_0 [mm]	h_2 [mm]	h_{nom} [mm]	l [mm]	t_{fix} [mm]		[pcs]
Item	gvz	A4	hdg								
SXR 10 x 52 FUS	502456 ¹⁾	—	—	■	10	62	50	52	2	T40/SW13	50
SXR 10 x 60 FUS	046329	046339	—	■	10	70	50	60	10	T40/SW13	50
SXR 10 x 60 FUS	—	—	509537	—	10	70	50	60	10	T40/SW13	50
SXR 10 x 80 FUS	046330	046340	—	■	10	90	50	80	30	T40/SW13	50
SXR 10 x 80 FUS	—	—	509538	—	10	90	50	80	30	T40/SW13	50
SXR 10 x 100 FUS	046331	046342	—	■	10	110	50	100	50	T40/SW13	50
SXR 10 x 100 FUS	—	—	509539	—	10	110	50	100	50	T40/SW13	50
SXR 10 x 120 FUS	046332	046343	—	■	10	130	50	120	70	T40/SW13	50
SXR 10 x 140 FUS	046333	046344	—	■	10	150	50	140	90	T40/SW13	50
SXR 10 x 140 FUS	—	—	509540	—	10	150	50	140	90	T40/SW13	50

1) not pre-assembled

TECHNICAL DATA



SXR-FUS - with fischer hexagon head safety screw, moulded washer and integrated T40 bit recess

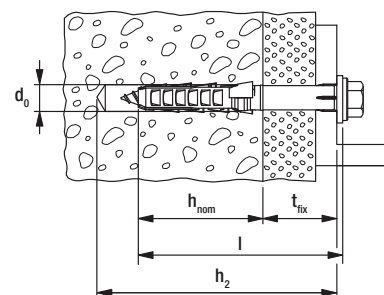

	Zinc-plated steel	Stainless steel	Hot-dip galvanized steel	Approval	Drill hole diameter	Min. drill hole depth for through fixings	Min. anchorage depth	Anchor length	Max. fixture thickness	Drive	Sales unit
	Art.-No.	Art.-No.	Art.-No.	ETA	d_0 [mm]	h_2 [mm]	h_{nom} [mm]	l [mm]	t_{fix} [mm]		[pcs]
Item	gvz	A4	hdg								
SXR 10 x 160 FUS	046334	046345	—	■	10	170	50	160	110	T40/SW13	50
SXR 10 x 180 FUS	046335	046361	—	■	10	190	50	180	130	T40/SW13	50
SXR 10 x 200 FUS	046336	046362	—	■	10	210	50	200	150	T40/SW13	50
SXR 10 x 230 FUS	046337	046363	—	■	10	240	50	230	180	T40/SW13	50
SXR 10 x 260 FUS	046338	046364	—	■	10	270	50	260	210	T40/SW13	50

1) not pre-assembled

ACCESSORIES



Cover cap **ADT**

Item	Art.-No.	Colour	Cap	Match	Sales unit
			[Ø mm]		[pcs]
ADT 15 W	060326	white	15	Safety screw with integrated bit recess T40	100
ADT 15 DB	060329	dark brown	15	Safety screw with integrated bit recess T40	100
ADT 18 W	060334	white	18	Safety screw with integrated bit recess T40	100
ADT 18 DB	060337	dark brown	18	Safety screw with integrated bit recess T40	100

ACCESSORIES



Washer **U**

Item	Art.-No.	External-Ø	Hole-Ø	Thickness	Matching anchor type	Sales unit
		d [mm]	D [mm]	S [mm]		[pcs]
U 11,5 x 21 x 1,5 DIN 522 A2	010026	21	11.5	1.5	SXR 10, SXRL 10, FUR 10	500

ACCESSORIES



Aircrete hole punch **GBS**

Item	Art.-No.	Drill hole	Min. drill hole depth for through fixings	Match	Sales unit
		d_0 [Ø mm]	h_2 [mm]		[pcs]
GBS 10 x 80	050590 1)	9	85	SXR 10 x 52, SXR 10 x 60, SXR 10 x 80	1
GBS 10 x 100	050591 1)	9	105	SXR 10 x 100	1
GBS 10 x 135	050593 1)	9	140	SXR 10 x 120	1
GBS 10 x 160	050594 1)	9	165	SXR 10 x 140, SXR 10 x 160	1
GBS 10 x 185	050595 1)	9	190	SXR 10 x 180	1
GBS 10 x 230	050596 1)	9	235	SXR 10 x 200, SXR 10 x 230	1

1) According to the ETA, the aircrete hole punch GBS must be used for drill-hole production in aerated concrete PB < 4N/mm².

LOADS

Frame fixing SXR⁴⁾

Highest permissible loads¹⁾²⁾ of a single anchor as part of a multiple fixing of non-structural systems.
For the design the complete assessment ETA-07/0121 has to be considered.

Product		SXR		
Anchor diameter		[mm]	Ø 8	Ø 10
Anchorage depth	h_{nom}	[mm]	50	50
Anchorage in concrete \geq C12/15				
Permissible tensile load		[kN]	0,99	1,79
Permissible shear load	Zinc-plated steel	[kN]	4,23	5,98
	Stainless steel A4	[kN]	3,93	5,98
Minimum member thickness	h_{min}	[mm]	100	100
Characteristic edge distance	$c_{cr,N}$	[mm]	70	140
Characteristic spacing	a resp. $s_{cr,N}$	[mm]	70	100
Minimum spacing	s_{min}	[mm]	70	70
with an edge distance	$c \geq$	[mm]	70	210
Minimum edge distance	c_{min}	[mm]	70	85
with a spacing	$s \geq$	[mm]	70	100
Anchorage in narrow concrete members ($h \geq 40$ mm) made of concrete \geq C12/15, e.g. weather shells of triple-skin outer wall panels				
Permissible tensile load		[kN]	-	1,19
Permissible shear load		[kN]	-	5,98
Anchorage in masonry				
Permissible load ³⁾ in solid brick	\geq Mz 12 a. \geq NF	[kN]	0,57	0,57
	\geq Mz 20 a. \geq NF	[kN]	0,71	0,86
Permissible load ³⁾ in solid sand-lime brick	\geq KS 10 a. \geq NF	[kN]	0,57	0,57
	\geq KS 20 a. \geq NF	[kN]	0,71	0,71
Permissible load ³⁾ in lightweight concrete block	\geq V 2; $\rho \geq 1,2$ kg/dm ³	[kN]	0,26	0,21
	\geq V 6; $\rho \geq 1,6$ kg/dm ³	[kN]	0,26	0,71
Permissible load ³⁾⁵⁾ in vertically perforated brick (e.g. Poroton)	\geq HLz 10; $\rho \geq 1,0$ kg/dm ³	[kN]	0,17	0,26
Permissible load ³⁾ in perforated sand-lime brick	\geq KSL 6	[kN]	0,26	0,43
	\geq KSL 12	[kN]	0,57	0,57
Permissible load ³⁾⁵⁾ in hollow lightweight concrete blocks	\geq HBL 2	[kN]	-	0,43
	\geq HBL 6	[kN]	0,43	0,57
Minimum member thickness	h_{min}	[mm]	100	100
Minimum spacing (single anchor)	a_{min}	[mm]	250	250
Minimum spacing (anchor group)	s_{min}	[mm]	100	100
Minimum edge distance (anchor group)	c_{min}	[mm]	100	100
Anchorage in aerated concrete				
Permissible load ³⁾ in aerated concrete	2 N/mm ²	[kN]	-	0,14 ⁶⁾
	4 N/mm ²	[kN]	-	0,27
	6 N/mm ²	[kN]	-	0,27
Minimum member thickness	h_{min}	[mm]	-	100
Minimum spacing (single anchor)	a_{min}	[mm]	-	250
Minimum spacing (anchor group)	s_{min}	[mm]	-	400
Minimum edge distance (anchor group)	c_{min}	[mm]	-	100

¹⁾ The required partial safety factors for material resistance as well as a partial safety factor for load actions $\gamma_L = 1,4$ are considered.
As a single anchor counts e.g. an anchor with a minimum spacing a according to table B4.1 resp. table B4.2 of the assessment.

²⁾ Valid for temperatures in the substrate up to +50 °C (resp. short term up to +80 °C). For long term temperatures up to +30 °C higher permissible loads may be possible.

³⁾ Valid for tensile load, shear load and oblique load under any angle. For combinations of tensile loads, shear loads and bending moments see assessment.

⁴⁾ Valid for zinc coated screws and for screws made of stainless steel. For exterior use of the zinc coated screws measures against incoming humidity according to assessment have to be taken.

⁵⁾ Rotary drilling.

⁶⁾ Drill holes to be made with aerated concrete hole punch.

LOADS

Frame fixing SXR³⁾

Highest recommended loads¹⁾ for a single anchor as part of a multiple fixing of non-structural systems.
The given loads are valid for wood screws with the specified diameter.

Type			SXR 6	SXR 8
Anchorage depth	h_{nom}	[mm]	30	50
Screw diameter	\emptyset	[mm]	4,5	6,0
Min. edge distance concrete	a_r	[mm]	50	60
Recommended loads in the respective base material F_{rec}²⁾				
Concrete	$\geq C20/25$	[kN]	0,25	0,40
Solid brick	$\geq Mz 12$	[kN]	0,20	0,30
Solid sand-lime brick	$\geq KS 12$	[kN]	0,20	0,30
Vertically perforated brick	$\geq Hlz 12 (\rho \geq 1,0 \text{ kg/dm}^3)$	[kN]	0,10	0,10
Perforated sand-lime brick	$\geq KSL 12$	[kN]	0,20	0,30

¹⁾ Required safety factors are considered.

²⁾ Valid for tensile load, shear load and oblique load under any angle.

³⁾ Valid for zinc coated screws and for screws made of stainless steel. For exterior use of the zinc coated screws measures against incoming humidity have to be taken.