

The cost-efficient fixing for flexible use in non-cracked concrete



Column bases



Stormwater overflow tank manholes

VERSIONS

- Zinc-plated steel
- Stainless steel
- Hot-dip galvanised steel (with variable working life for outdoor areas)

BUILDING MATERIALS

Approved for:

- Concrete C20/25 to C50/60, non-cracked

Also suitable for:

- Concrete C12/15
- Natural stone with dense structure

CERTIFICATES

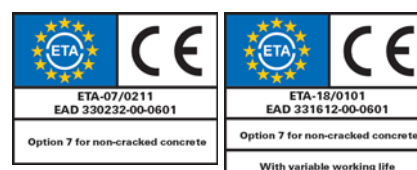

ADVANTAGES

- The standard anchorage depth achieves the maximum load-bearing capacities.
- The reduced anchorage depth reduces the drill hole depth. This minimises the amount of time needed for installation whilst increasing flexibility.
- Additional short version „K“ with short anchoring depth.
- The long thread balances component tolerances and allows for stand-off installations, thus increasing flexibility.
- Few hammer blows and the minimal torque slippage allow for a noticeably simpler installation.
- The drive-in pin protects the thread from damage, and thus ensures a faster installation and dismantling of the attachment.
- The larger washer included with the FBN II GS creates a larger supporting surface and, as such, allows for the fixing of wood constructions.
- When using hollow drills with suction is no drill hole cleaning required.
- New ETA assessment for hot-dip galvanised version for variable working life in outdoor areas.

APPLICATIONS

- Steel constructions
- Guard rails
- Consoles
- Ladders
- Cable trays
- Machines
- Staircases
- Gates
- Façades

FUNCTIONING

- The FBN II is suitable for pre-positioned and push-through installation; also suitable for stand-off installation under certain conditions.
- Prior to installation, place the hexagon nut in the optimal position (the drive-in pin projects by approx. 3 mm out of the hexagon nut).
- When applying the torque, the cone bolt is pulled into the expansion clip and expands it against the drill hole wall.
- The head embossing offers a simple control of the anchoring.
- In the case of series installation, we recommend using the FABS bolt anchor setting tool.

INSTALLATION

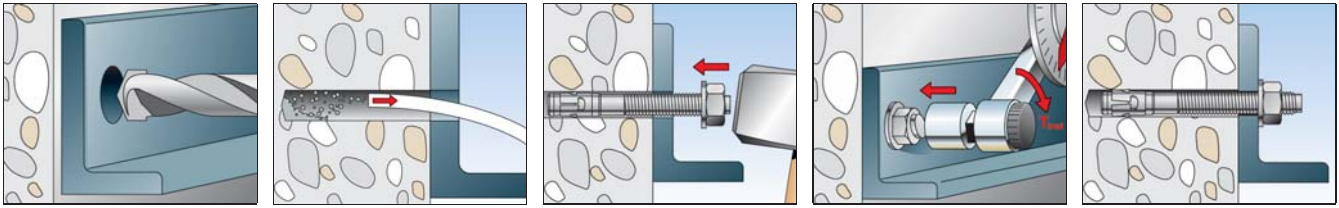

TECHNICAL DATA



Bolt anchor **FBN II**

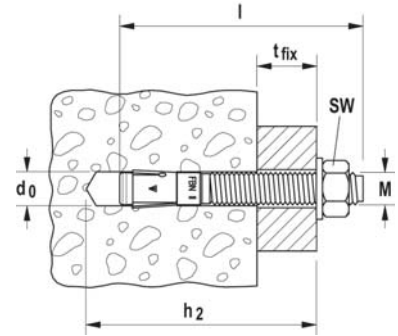

Item	Zinc-plated steel	Stainless steel	Hot-dip galvanized steel	Approval ETA	Drill hole diameter	Min. drill hole depth for through fixings	Anchor length	Max. usable length hef,max./hef,min.	Thread	Width across nut	Sales unit
	Art.-No.	Art.-No.	Art.-No.		d_0 [mm]	h_2 [mm]	l [mm]	t_{fix} [mm]	$\emptyset \times$ length [mm]	\emptyset SW [mm]	[pcs]
	gvz	A4	hdg								
FBN II 6/5	505526 ¹⁾²⁾	—	—	■	6	45	50	5/-	M 6 x 12	10	100
FBN II 6/10	505527 ¹⁾²⁾	505532 ¹⁾²⁾	—	■	6	50	55	10/-	M 6 x 17	10	100
FBN II 6/30	505528 ¹⁾²⁾	505535 ¹⁾²⁾	—	■	6	70	75	30/-	M 6 x 35	10	100
FBN II 8/5	040662	—	—	■	8	61	66	5/15	M 8 x 34	13	50
FBN II 8/10	040664	507555	507575	■	8	66	71	10/20	M 8 x 39	13	50
FBN II 8/20	040669	—	—	■	8	76	81	20/30	M 8 x 49	13	50
FBN II 8/30	040700	507556	507576	■	8	86	91	30/40	M 8 x 59	13	50
FBN II 8/50	040771	507557	507577	■	8	106	111	50/60	M 8 x 79	13	50
FBN II 8/70	040777	—	507578	■	8	126	131	70/80	M 8 x 99	13	20
FBN II 8/100	040783	—	—	■	8	156	161	100/110	M 8 x 129	13	20
FBN II 10/10	040827	507558	507579	■	10	78	86	10/20	M 10 x 46	17	50
FBN II 10/20	040851	507559	—	■	10	88	96	20/30	M 10 x 56	17	50
FBN II 10/30	040854	—	—	■	10	98	106	30/40	M 10 x 66	17	—
FBN II 10/30	—	507560	507580	■	10	98	106	30/40	M 10 x 66	17	50
FBN II 10/50	040855	507561	507582	■	10	118	126	50/60	M 10 x 86	17	20
FBN II 10/70	040931	—	—	■	10	138	146	70/80	M 10 x 106	17	20
FBN II 10/100	040943	507562	507583	■	10	168	176	100/110	M 10 x 136	17	20
FBN II 10/140	040944	—	—	■	10	208	216	140/150	M 10 x 176	17	20
FBN II 10/160	040945	—	—	■	10	228	236	160/170	M 10 x 196	17	20
FBN II 12/10	040950	507563	507589	■	12	95	106	10/25	M 12 x 59	19	20
FBN II 12/20	044558	507564	—	■	12	105	116	20/35	M 12 x 69	19	20
FBN II 12/30	045263	507565	507591	■	12	115	126	30/45	M 12 x 79	19	20
FBN II 12/50	045264	507566	507592	■	12	135	146	50/65	M 12 x 99	19	20
FBN II 12/80	045265	—	—	■	12	165	176	80/95	M 12 x 129	19	20
FBN II 12/100	045266	507567	507596	■	12	185	196	100/115	M 12 x 149	19	20
FBN II 12/120	045267	—	—	■	12	205	216	120/135	M 12 x 169	19	20
FBN II 12/140	045268	—	—	■	12	225	236	140/155	M 12 x 189	19	20
FBN II 12/160	045269	—	—	■	12	245	256	160/175	M 12 x 189	19	20
FBN II 16/10	—	507568	—	■	16	114	130	10/25	M 16 x 74	24	10
FBN II 16/25	045564	507569	507598	■	16	129	145	25/40	M 16 x 89	24	10
FBN II 16/50	045565	507570	507553	■	16	154	170	50/65	M 16 x 105	24	10
FBN II 16/80	045566	—	—	■	16	184	200	80/95	M 16 x 144	24	10
FBN II 16/100	045567	—	507554	■	16	204	220	100/115	M 16 x 164	24	10
FBN II 16/140	045568	—	—	■	16	244	260	140/155	M 16 x 184	24	10

1) Use restricted to anchoring of structural components which are statically indeterminate.

2) Nut and washer not pre-assembled/supplied loose.

TECHNICAL DATA



Bolt anchor **FBN II**

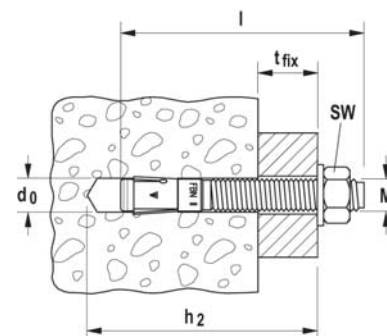

	Zinc-plated steel	Stainless steel	Hot-dip galvanised steel	Approval	Drill hole diameter	Min. drill hole depth for through fixings	Anchor length	Max. usable length hef,max./hef,min.	Thread	Width across nut	Sales unit
	Art.-No.	Art.-No.	Art.-No.	ETA	d_0 [mm]	h_2 [mm]	l [mm]	t_{fix} [mm]	$\emptyset \times$ length [mm]	\circ SW [mm]	[pcs]
Item	gvz	A4	hdg								
FBN II 16/160	045569	—	—	■	16	264	280	160/175	M 16 x 184	24	10
FBN II 16/200	045570	—	—	■	16	304	320	200/215	M 16 x 184	24	10
FBN II 20/30	045573	507571	508015	■	20	165	187	30/55	M 20 x 90	30	10
FBN II 20/60	045574	507572	—	■	20	195	217	60/85	M 20 x 90	30	10
FBN II 20/80	045575	—	—	■	20	215	237	80/105	M 20 x 90	30	10
FBN II 20/120	045576	—	—	■	20	255	277	120/145	M 20 x 90	30	10

1) Use restricted to anchoring of structural components which are statically indeterminate.

2) Nut and washer not pre-assembled/supplied loose.

TECHNICAL DATA



Bolt anchor **FBN II K**

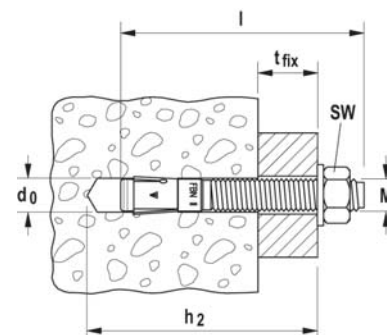

	Zinc-plated steel, short version	Stainless steel, short version	Hot-dip galvanised steel, short version	Approval	Drill hole diameter	Min. drill hole depth for through fixings	Anchor length	Max. usable length hef,max./hef,min.	Thread	Width across nut	Sales unit
	Art.-No.	Art.-No.	Art.-No.	ETA	d_0 [mm]	h_2 [mm]	l [mm]	t_{fix} [mm]	$\emptyset \times$ length [mm]	\circ SW [mm]	[pcs]
Item	gvz	A4	hdg								
FBN II 8/5 K	040806	508007	508012	■	8	51	56	-/5	M 8 x 24	13	50
FBN II 8/10 K	040807	—	—	■	8	56	61	-/10	M 8 x 29	13	50
FBN II 10/5 K	040946	508010	508013	■	10	63	71	-/5	M 10 x 31	17	50
FBN II 10/10 K	040947	—	—	■	10	68	76	-/10	M 10 x 36	17	50
FBN II 12/5 K	045272	508011	508014	■	12	75	86	-/5	M 12 x 39	19	20
FBN II 12/10 K	045273	—	—	■	12	80	91	-/10	M 12 x 44	19	20
FBN II 12/30 K	045274	—	—	■	12	100	111	-/30	M 12 x 64	19	20
FBN II 16/15 K	045571	508745	507597	■	16	104	120	-/15	M 16 x 64	24	10
FBN II 16/25 K	045572	—	—	■	16	114	130	-/25	M 16 x 74	24	10
FBN II 20/10 K	045577	—	—	■	20	120	142	-/10	M 20 x 50	30	10

TECHNICAL DATA



Bolt anchor **FBN II-GS** with large washer

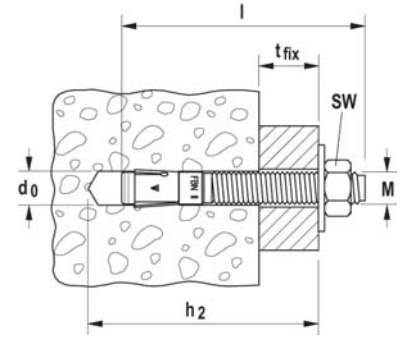

High performance steel anchors 4

Item	Steel, zinc-plated, with large washer	Approval ETA	Drill hole diameter	Min. drill hole depth for through fixings	Anchor length	Max. usable length hef,max./hef,min.	Thread	Width across nut	Washer (outer diameter x thickness)	Sales unit
	Art.-No.		d_0 [mm]	h_2 [mm]	l [mm]	t_{fix} [mm]	\emptyset x length [mm]	\emptyset SW [mm]	[mm]	[pcs]
	gvz									
FBN II 12/80 GS	045578	■	12	165	176	80/95	M 12 x 129	19	44 x 4	20
FBN II 12/100 GS	045579	■	12	185	196	100/115	M 12 x 149	19	44 x 4	20
FBN II 12/120 GS	045580	■	12	205	216	120/135	M 12 x 169	19	44 x 4	20
FBN II 12/140 GS	045581	■	12	225	236	140/155	M 12 x 189	19	44 x 4	10
FBN II 12/160 GS	045583	■	12	245	256	160/175	M 12 x 189	19	44 x 4	10
FBN II 12/180 GS	045584	■	12	265	276	180/195	M 12 x 189	19	44 x 4	10
FBN II 12/200 GS	045585	■	12	285	296	200/215	M 12 x 189	19	44 x 4	10
FBN II 12/250 GS	045586	■	12	335	346	250/265	M 12 x 100	19	44 x 4	10
FBN II 16/100 GS	045588	■	16	204	220	100/115	M 16 x 164	24	56 x 5	10
FBN II 16/140 GS	045590	■	16	244	260	140/155	M 16 x 184	24	56 x 5	10
FBN II 16/160 GS	045591	■	16	264	280	160/175	M 16 x 184	24	56 x 5	10
FBN II 16/200 GS	045593	■	16	304	320	200/215	M 16 x 100	24	56 x 5	10

ACCESSORIES



fischer Anchor bolt setting tool **FABS**

Item	Art.-No.	Matching anchor type	Sales unit [pcs]
FABS	077937	FAZ II, FBN II, EXA for diameter from M6 - M12	1

LOADS

Bolt anchor FBN II

zinc plated steel / stainless steel / hot dip galvanised steel

Permissible loads of a single anchor in non-cracked normal concrete (concrete compression zone) of strength class C20/25 (~B25) ¹⁾²⁾³⁾										Minimum spacings while reducing the load	
Type	Material fixing element	Min. member thickness	Effective anchorage depth	Installation torque	Permissible tensile load	Permissible shear load	Required edge distance (with one edge) for		Required spacing for	Min. spacing	Min. edge distance
							Max. tension load c	Max. shear load c			
		h_{min} [mm]	h_{ef} [mm]	T_{inst} [Nm]	$N_{perm}^{4)}$ [kN]	$V_{perm}^{4)}$ [kN]	[mm]	[mm]	Max. Load s [mm]	$s_{min}^{5)6)}$ [mm]	$c_{min}^{5)6)}$ [mm]
FBN II 6	gvz	100	30 ⁸⁾	4	2,9	3,4	100	60	90	40	40
	A4			4	2,9	3		55			
FBN II 8	gvz	100	30 ⁸⁾	15	2,9	7,1	65	115	90	40	40
	A4			10	2,9	7,1		115		50	45
	gvz	100	40	15	6,1	7,6	95	120	120	40	40
	A4			10		7,3		115			45
	hdg			15		7,6		120			40
FBN II 10	gvz	100	40	30	6,1	12,0	100	190	120	50	80
	A4			20		11,6		185			
	gvz	100	50	30	8,5	12,0	100	185	150	50	50
	A4			20		11,6		180		70	55
	hdg			30		12,0		185		50	50
FBN II 12	gvz	100	50	50	8,5	17,9	145	280	150	70	100
	A4			35		15,7		245			
	gvz	120	65	50	12,6	17,9	145	245	195	70	70
	A4			35		15,7		215			
	hdg			40		17,9		245			
FBN II 16	gvz	120	65	100	12,6	29,0	175	410	195	90	120
	A4			80							
	gvz	160	80	100	17,2	31,5	175	375	240	90	90
	A4			80		29,1		340		120	80
	hdg			70		31,5		375		90	90
FBN II 20	gvz	160	80	200	17,2	38,3	185	455	240	120	120
	A4			150		39,6		470		140	
	gvz	200	105	200	25,9	38,3	185	385	315	120	120
	A4			150		49,1		510			
	hdg			200		38,3		385			

For the design the complete assessment ETA-07/0211 has to be considered. ⁷⁾

¹⁾ The partial safety factors for material resistance as regulated in the ETA-07/0211 as well as a partial safety factor for load actions of $\gamma_L = 1,4$ are considered. As an single anchor counts e.g. an anchor with a spacing $s \geq 3 \cdot h_{ef}$ and an edge distance $c \geq 1,5 \cdot h_{ef}$. Accurate data see ETA-07/0211.

²⁾ For higher concrete strength classes up to C50/60 higher permissible loads may be possible.

³⁾ Drill method Hammer drilling resp. hollow drilling.

⁴⁾ For combinations of tensile loads, shear loads, bending moments as well as reduced edge distances or spacings (anchor groups) see ETA-07/0211.

⁵⁾ Minimum possible axial spacings resp. edge distance while reducing the permissible load.

⁶⁾ Minimum possible spacing resp. edge distance while reducing the permissible load for the required minimum member thickness. The combination of minimum edge distance and minimum spacing is not possible. One of both values has to be increased acc. ETA-07/0211.

⁷⁾ The given loads refer to the European Technical Assessment ETA-07/0211, issue date 19/05/2016. Design of the loads according ETAG 001, Annex C, Method A (for static resp. quasi-static loads).

⁸⁾ Anchoring depth smaller than 40 mm are only approved for statically indeterminate systems.